

14 x 14M THICKNESS 14CM SPRUNG FLOORS WITH MOUNTED & NOT MOUNTED SPRINGS «MONTREAL» COMPETITION EXERCISE FLOOR M'24

6792-6793
6775F-6775F/DE
6776D-6776D/DE

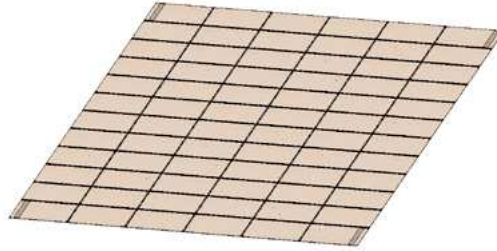

6775F & 6775D/DE
6776D & 6776D/DE



**KEEP THIS
DOCUMENT**

Warning:

This equipment should be installed by a qualified individual. This equipment should only be used by one person at a time, under the supervision of a qualified individual.

Using this equipment for purposes other than those originally intended is prohibited.

Compliance:

14 x 14 m Exercise floors references **6775F & 6775F/DE & 6776D & 6776D/DE**, are FIG approved.

Recommendations:

- Keep these instructions for subsequent reference (inspection, maintenance, etc.).
- Periodically carry out predictive maintenance.
- Depending on how much it is used have the equipment serviced yearly or every few years.

Maintenance:



IMPORTANT :

- Regular cleaning of the exercise floor makes it easier to spot any problems (distortion, breakage or moisture absorption).
- Check on the presence and condition: of the profiles **(7)**, **(8)**, and linking plates **(9) & (10)** properly locked.
- Check the condition of the floor: wood panels **(4)**, **(5)**, **(6)**, springs **(2)** and plastic parts **(1) & (3)**,
- Check the condition of the floor anti-rotation kit **(NM311)**.
- Check the condition of the foams area **(NM309)**, and the carpet **(NM310)** or roll-up tracks **(NM286)**.
- Any damaged or distorted component should be replaced as quickly as possible.

Composition :

1/ 14 x 14M «MONTREAL» COMPETITION EXERCISE FLOOR WITH MOUNTED & NOT MOUNTED SPRINGS CARPET VERSION (REF.: 6775F & 6775F/DE):

- Overlay carpet 14 x 14m (Ref: **6380I**) -> Detailed Pack list: refer to instructions **NM310**.
- Set of 4 finishing bibs 14m (Ref: **6575/10**): Volume 0.06 m³, Weight 9.5 kg, Dimensions 600 x 420 x 240 mm -> instructions **NM309**.
- Impact-absorbing foam area 14 x 14m - thickness: 56 mm (Ref: **6789**) -> Detailed Pack list: refer to instructions **NM309**.
- High elasticity floor 14 x 14m with springs mounted (Ref: **6792**) or springs not mounted (Ref: **6793**).
- Floor Anti-Rotation Kit - 4 adjustable cables (Ref: **6529/00**) -> Detailed Pack list: refer to instructions **NM311** (included in floor).

2/ 14 x 14M «MONTREAL» COMPETITION EXERCISE FLOOR WITH MOUNTED & NOT MOUNTED SPRINGS ROLL-UP TRACKS VERSION (REF.: 6776D & 6776D/DE):

- Gymnastics Area 14x14m th. : 3.8cm «Montreal» evol. Comp. Exercise floor M'20 (Ref.: **6776/00**) -> Detailed Pack list: refer to instructions **NM286**.
- Set of 4 finishing bibs 14 m (Ref: **6575/10**): Volume 0.06 m³, Weight 9.5 kg, Dimensions 600 x 420 x 240 mm -> instructions **NM286**.
- Foam underlay 14x14m thickness: 24mm Exercise floor M'20 (Ref.: **6776/10**) -> Detailed Pack list: refer to instructions **NM285**.
- High elasticity floor 14 x 14 m with springs mounted (Ref: **6792**) or springs not mounted (Ref: **6793**).
- Floor Anti-Rotation Kit - 4 adjustable cables (Ref: **6529/00**) -> Detailed Pack list: refer to instructions **NM311** (included in floor).

Pack list:

Ref.	6529/00	6785/100	6785/120	6785/60	6792/00
Description	Anti-Rotation Floor Kit Package	Package of 5 complete black zinc-plated springs with screw	Set of 34 lockable plates (white color)	Set of 66 white & grey lockable plates	Pallet of 24 floor panels 2.33 x 1.16m for floor exercise area
6792	1	1	1	1	2
6793	1	1	1	1	-
Volume (m ³)	0.013	0.005	0.029	0.03	5.7848
Weight(kg)	4.2	1.17	1.99	3.64	807.0
Dimensions (mm)	310x210x200	200x160x150	410x320x220	410x320x230	2360x1180x2100

Ref.	6792/10	6792/20	6792/30	6793/00	6793/10	6793/36	6793/30	No.pkgs
Description	Pallet - 20 panels (2.33 x 1.16m) + 4 corner panels	Pkg - 18 H-profiles, 2.18 m	Pkg - 34 H-profiles, 1.015 m	Pallet containing 36 panels (2.33 x 1.16m) for spring floor with removable springs	Pallet - 32 panels (2.33 x 1.16m) + 4 corner panels - for floor exercise area	Palet of 36 Packs of 80 springs	Pkg of 1,440 lower spring mounts for floor exercise area	
6792	1	4	2	-	-	-	-	13
6793	-	4	2	1	1	1	2	15
Volume (m ³)	5.792	0.033	0.031	2.952	3.272	1.44	0.195	
Weight (kg)	807.0	23.5	21.0	886.0	916	500.0	22.0	
Dimensions (mm)	2360x1180x2080	2170x220x70	1010x220x140	2360x1180x1060	2350x1180x1180	1200x1200x100	1300x250x600	

I. Assembling the floor not mounted springs (Ref.: 6793) of exercise floors Refs.: 6775F/DE & 6776D/DE

Figures 1 & 2 - Clipping of springs and lower supports under floor panels

- Align vertically: the upper support (1), the spring only (2) and the lower support (3) screwed to the floor panels (p).
- Press hard on the upper support (1) to solidarize the elements simultaneously.
- The two «clacks» ensure that the three elements are correctly connected.

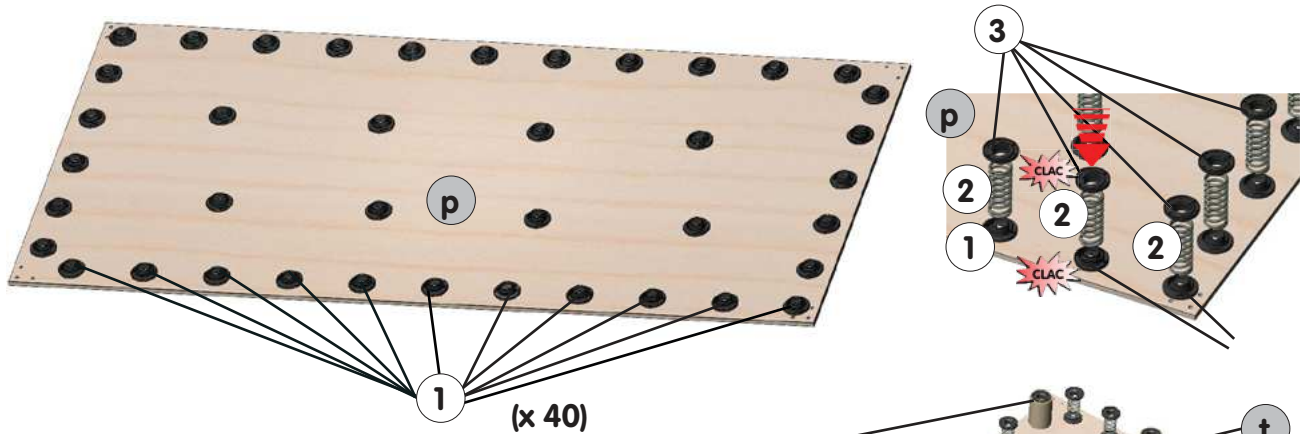

II. Assembling the floor: (2 minimum).



IMPORTANT: CHECK THAT THE PACKAGING TUBES (†) OF THE PANELS (REF.: 6792)

ARE COMPLETELY REMOVED DURING ASSEMBLY.

STORE THEM FOR FUTURE STORAGE AND/OR TRANSPORT.

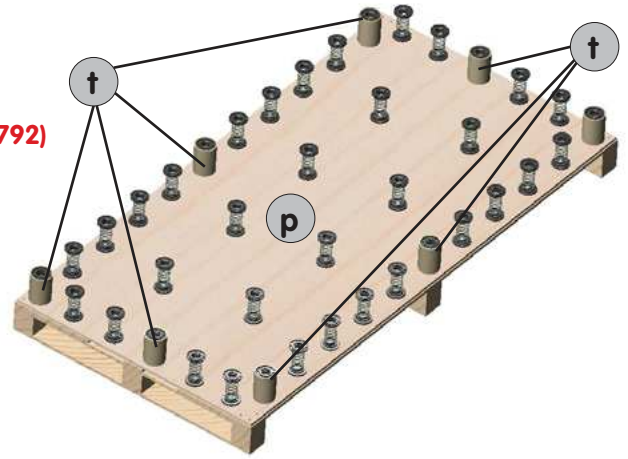
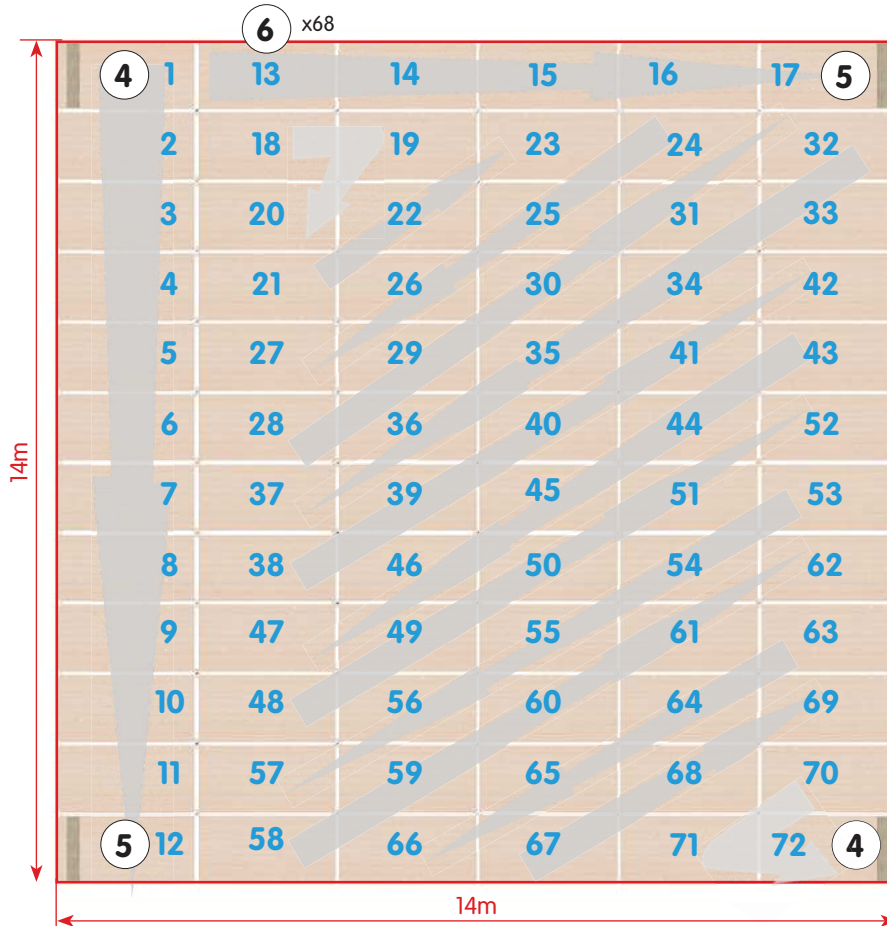

Figure 3 - Arrangement and order of the panels assembly

- On the ground, mark the overall dimensions of the floor: a 14 x 14 m square (Checking the diagonals: 19.82m)
- Assemble the 72 panels (4), (5) & (6) start with 1 left corner panel (4), then follow the specified order (Blue N°)



Figures 4, 5, 6, 7 & details - Orientation of the 4 corner panels

- ! ATTENTION, THESE 4 PANELS (4) AND (5) ARE EQUIPPED WITH:**
- Hook-and-loop strips (**m**) of the foam ARK, to be placed on the periphery of the floor
 - And guying plates (**h**), provided for the hooking of the cables (**c**) of the floor ARK, to be orientated towards the interior of the floor.

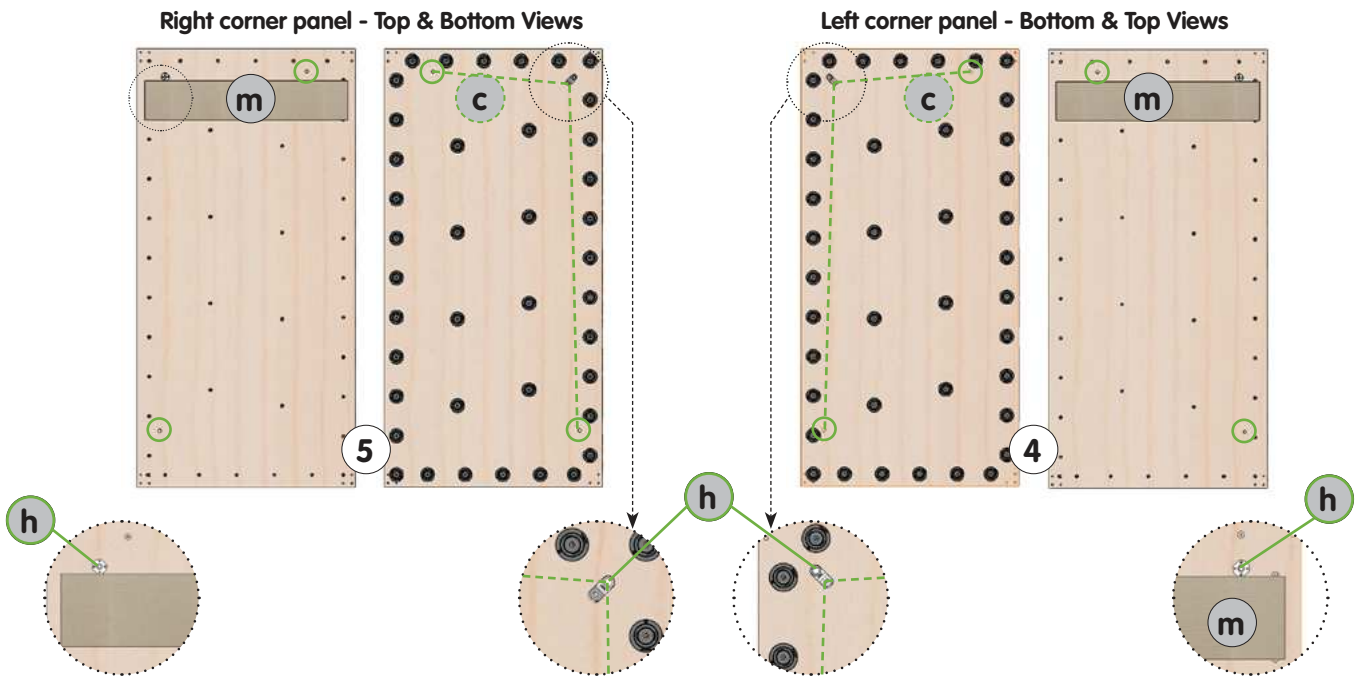

Figure 8 - Distribution of floor panels and connecting parts

- Assemble the white profiles (**7**) & (**8**) and the white & grey locking plates (**9**) on the central part (Connection between 4 panels).
- Assemble white locking plates (**10**) on the periphery of the floor (Connection between 2 panels).

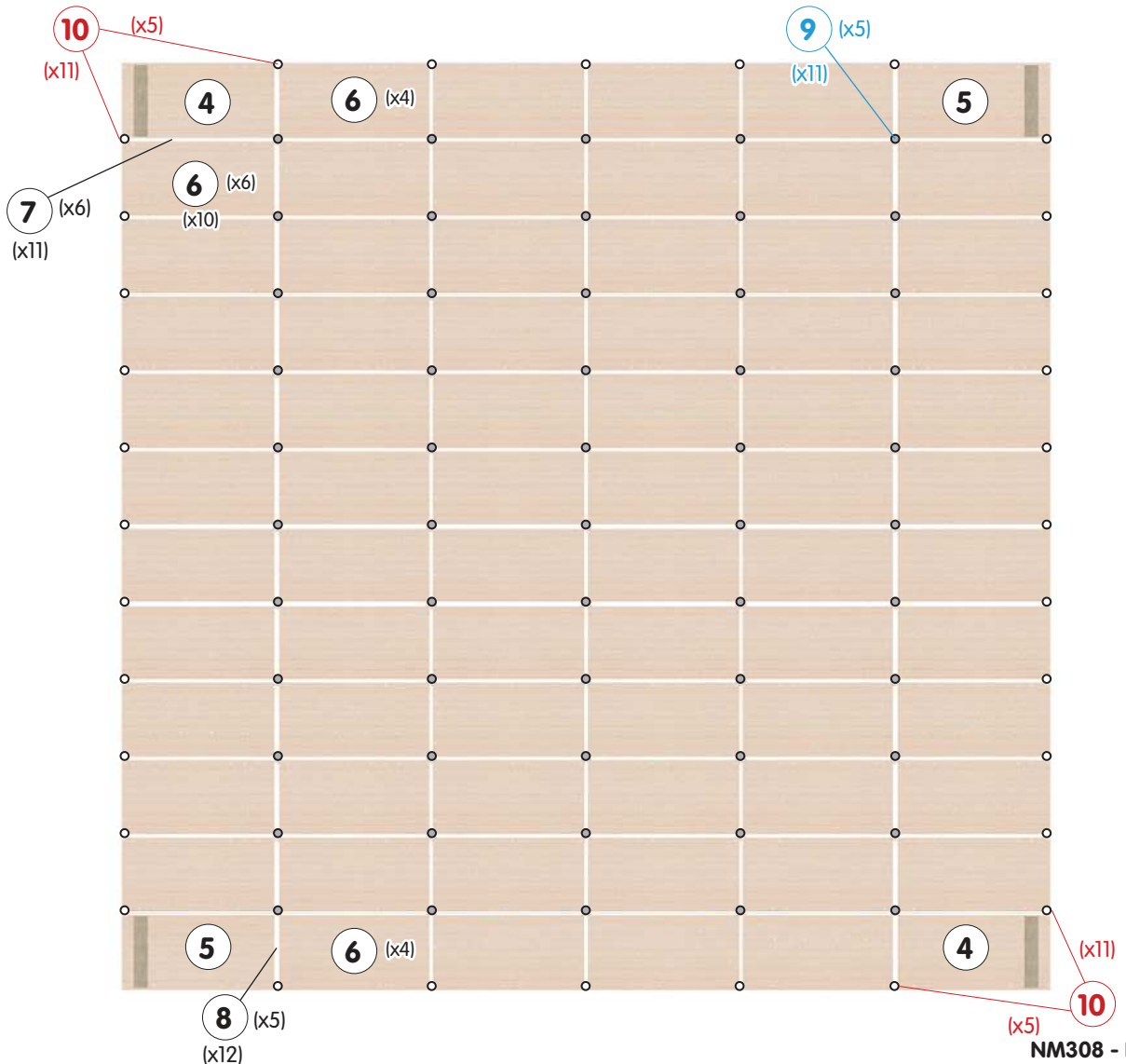
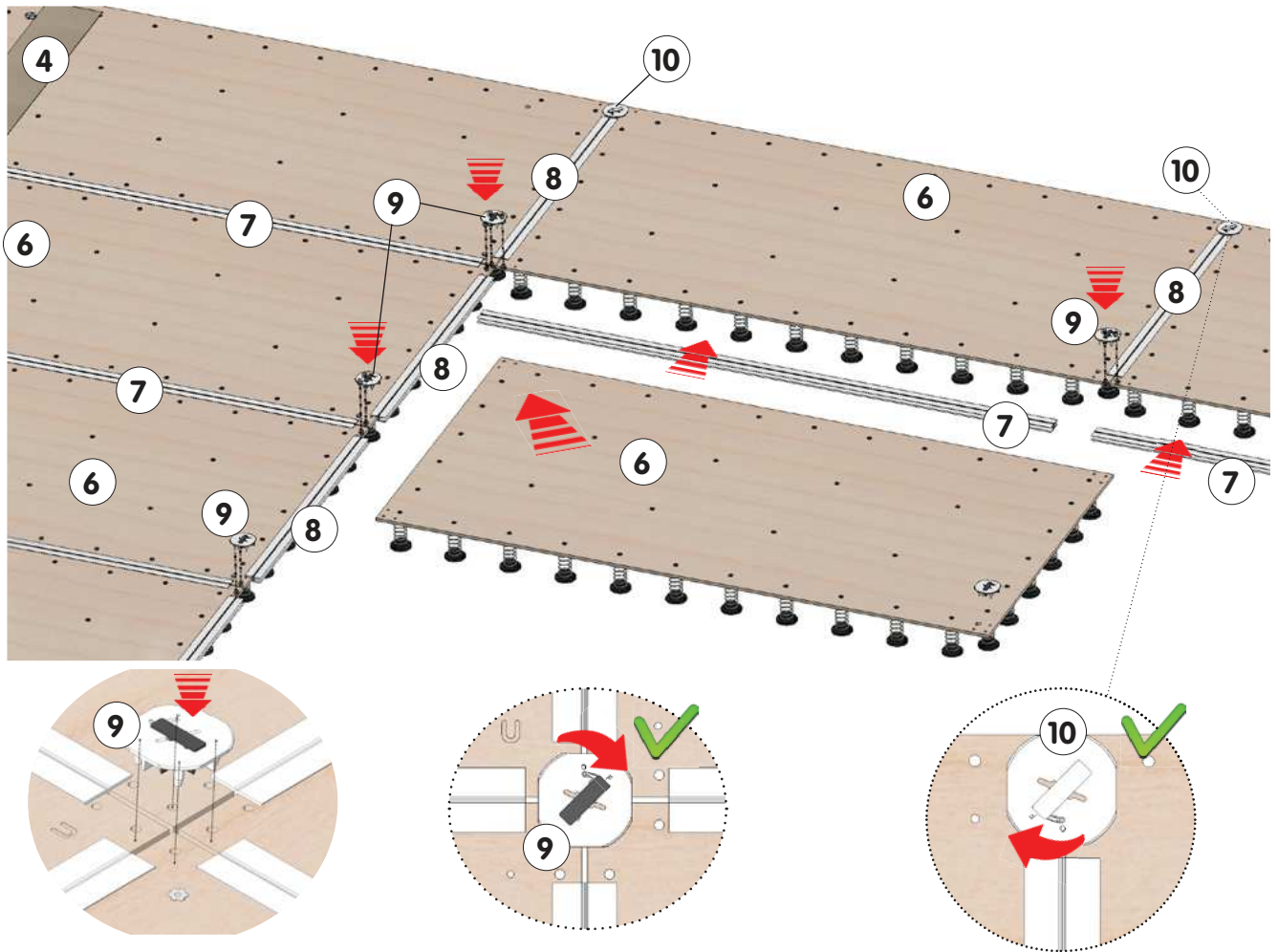

Figure 9 & details - Installation of the connecting parts

- Mount the locking plates (9) & (10) and the profiles (7) & (8) as the panels are assembled.
- Center the profiles on each side of the floor panels (4), (5) & (6).
- Lock the plates (9) & (10) ✓.



- Install the 4 cables from the Floor Anti-Rotation Kit (11) according to the instructions in manual **NM311**.

III. Assembling the impact-absorbing foam area:

- Exercise floor Refs.: 6775F - 6775F/DE -> Foam area 14 x 14m - th.: 56mm (Réf.: 6788C) : refer to instructions NM309.
- Exercise floor Refs.: 6776D - 6776D/DE -> Foam underlay 14x14m thickness: 24mm (Ref.: 6776/10) : refer to instructions NM285.

IV. Assembling the overlay carpet or roll-up tracks evolution area:

- Exercise floor Refs.: 6775F - 6775F/DE -> Carpet 14 x 14m (Réf.: 6380I) : efer to instructions NM310.
- Exercise floor Refs.: 6776D - 6776D/DE -> Roll-up tracks area 14x14m th: 38mm (Ref.: 6776/00) : refer to instructions NM286.

V. Disassembling and storing the floor: (2 minimum).

Figure 10 & details - Disassembling the floor

- Dismantle the Anti-Rotation Kit.
- **Unlock the plates (9) & (10)** ✓
- Dislodge the locking plates (9) & (10) and remove the profiles (7) & (8).
- Dismantle the floor panels (4), (5), (6) as you go.

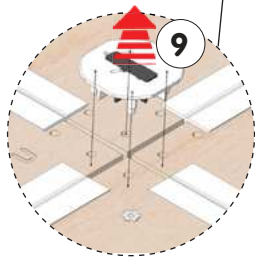
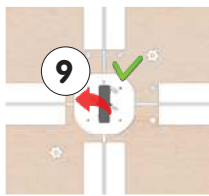
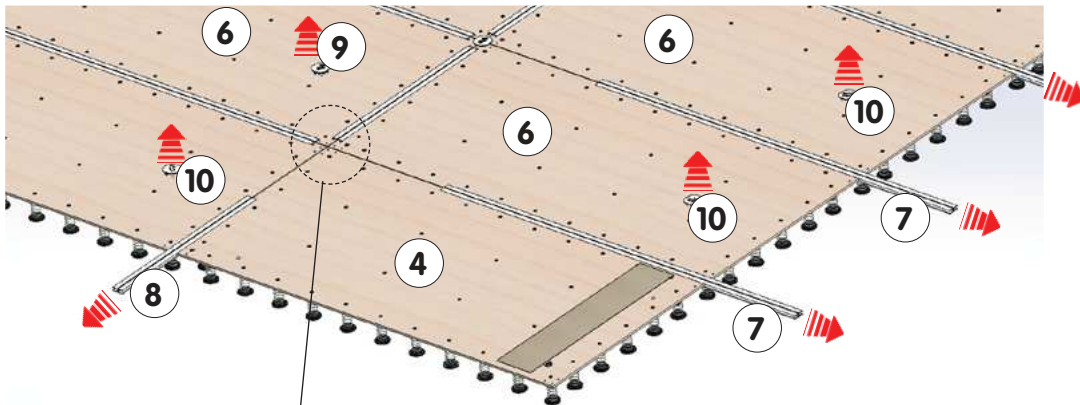

Figures 13, 14 & 15 - Prolonged storage

- It is imperative to stack the floor panels (4), (5) & (6) horizontally, nested 2 to 2 in each other.
- Use the 8 original cardboard tubes (t) between the panels

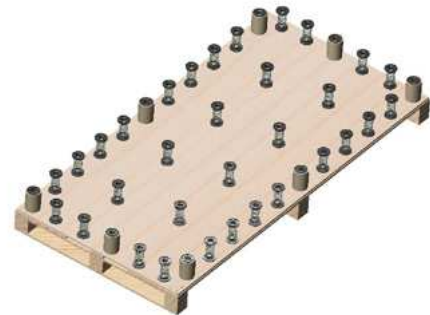

Figures 11 & 12 - Frequent storage for short periods

- Store floor panels (4), (5), (6) well vertically, nested 2 to 2 in each other.

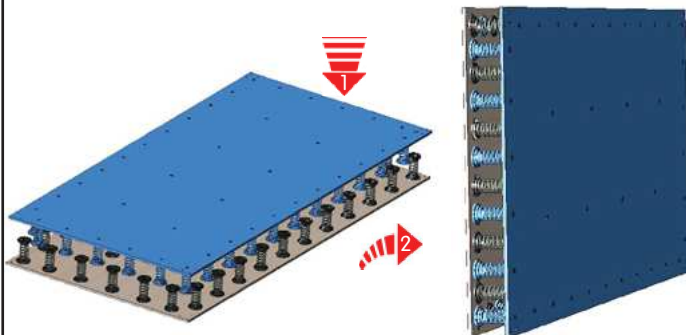

IMPORTANT:
STRAPS (S) MANDATORY
FOR TRANSPORT.

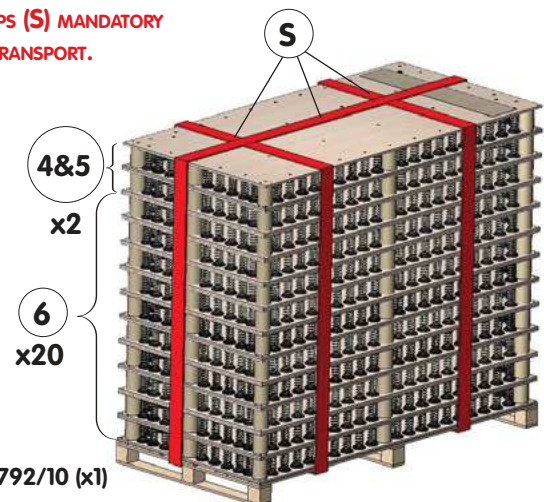
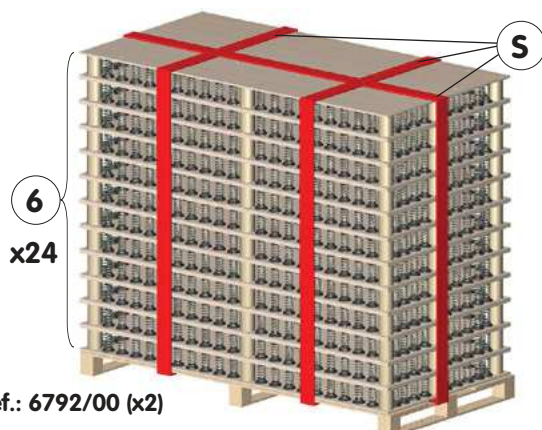

«MS» : Mounted Springs - «NMS» : Not Mounted Springs

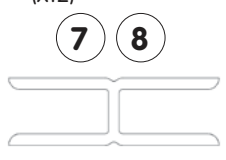
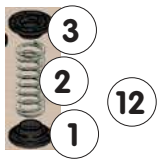
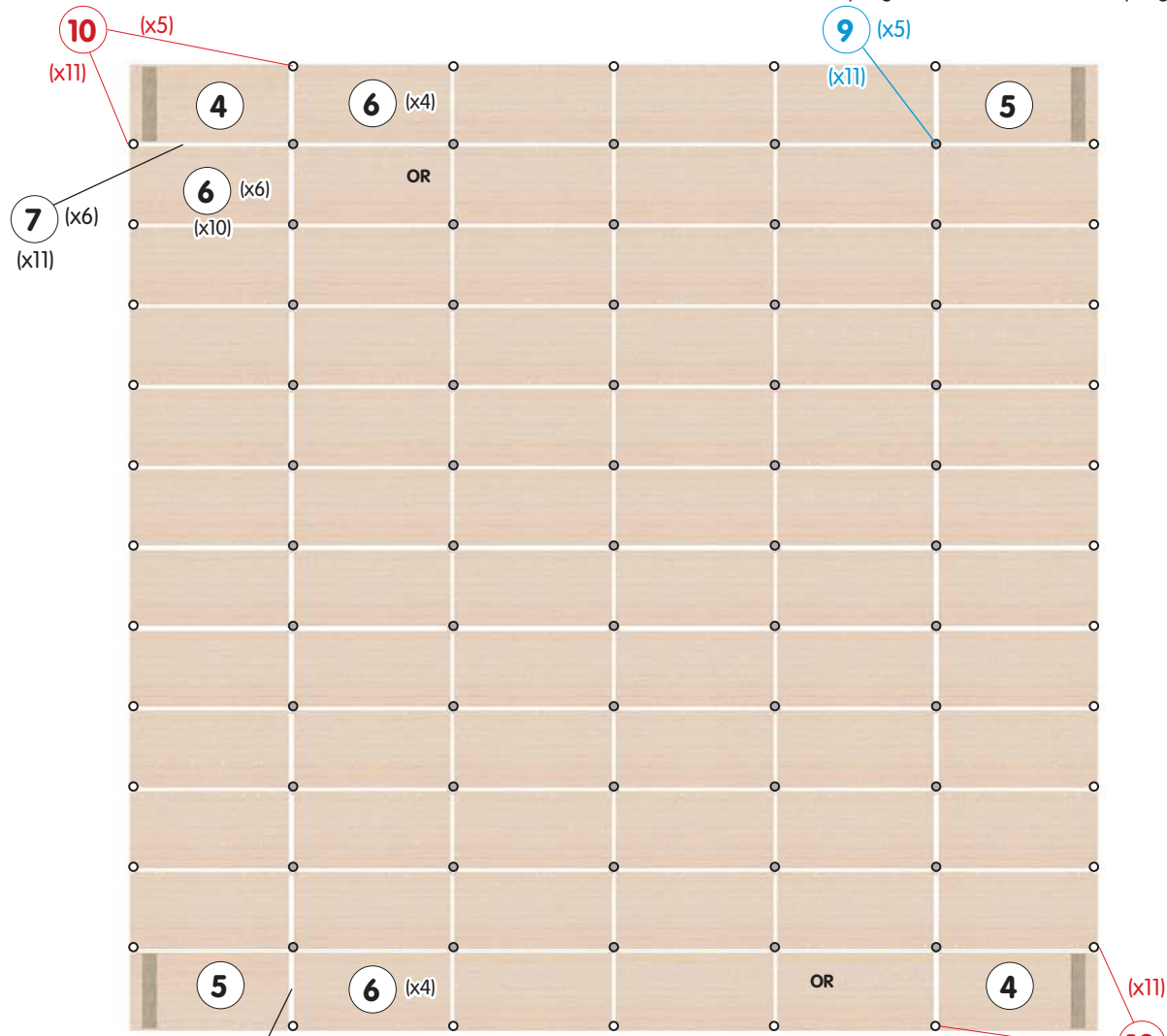

27	-	-	-	-
26	-	-	-	-
25	-	-	-	-
24	-	-	-	-
23	-	-	-	-
22	-	-	-	-
21	-	-	-	-
20	-	-	-	-
19	-	-	-	-
18	-	-	-	-
17	-	-	-	-
16	-	-	-	-
15	-	-	-	-
14	-	-	-	-
13	-	Set of 290 cardboard tubes / storage	6785/50	H. 13cm
12	1	Set of 5 mounted springs + fixings	6785/100	H. 13cm
11	1	Floor Anti-Rotation Kit -4 cables	6785/123	Complete NM311
10	32	2 ribs locking plate + Lock White	6785/73	Unit - periphery
9	55	4 ribs locking plate + Lock Grey	6785/63	Unit - central part
8	60	White connecting profile Length 1.02m	6792/31	-
7	66	White connecting profile Length 2.18m	6792/21	-
6'	68	2.33x1.16m Central panel NMS	6793/11	-
6	68	2.33x1.16m Central panel MS	6792/11	-
5'	2	2.33x1.16m Right corner panel NMS	6793/13	-
5	2	2.33x1.16m Right corner panel MS	6792/13	-
4'	2	2.33x1.16m Left corner panel NMS	6793/12	-
4	2	2.33x1.16m Left corner panel MS	6792/12	-
3	2880	Spring lower support	-	-
2	2880	Black spring only diam. 4 - H. 12.5cm	-	-
1	2880	Spring upper support	-	-
ITEM	QTY	DESCRIPTION	REFERENCE	REMARKS

14 x 14M THICKNESS 14CM SPRUNG FLOORS WITH MOUNTED & NOT MOUNTED SPRINGS «MONTREAL» COMPETITION EXERCISE FLOOR M'24

To order spare parts, please provide the description, reference and delivery date of the entire apparatus.

Constantly aiming to improve our products, we reserve the right to make changes to the equipment and dimensions without further discussion.

This document is the propriety of Gymnova, it is confidential and shall not be reproduced.

**STOPPER CABLES AND ANTI-ROTATION KITS FOR
14 X 14M & 12.85 X 12.85M
FLOORS OF «MONTREAL» SPRUNG EXERCISE FLOORS M'25.****6529/00
6529D****DOCUMENT À
CONSERVER****Warning :**

This equipment should be installed by a qualified individual. The attachments that are provided with these kits may only be used if the support complies with specification CC78. Using this equipment for purposes other than those originally intended is prohibited.

Recommendations:

- As set out in French Standard NF S52-400 the following is recommended:
- keep these instructions for subsequent reference (inspection, maintenance, etc.).
- periodically carry out predictive maintenance.
- depending on how often it is used, have the equipment serviced yearly or every few years.

Pack list :

1 Pack (Ref: **6529/00**) -> Set of 4 adjustable stopper cables + floor attachments:

Weight: 4.5 kg Dimensions: 310 x 210 x 200 mm Volume: 0.01 m³

1 Pack (Ref: **6529D**) -> Set of 4 complete adjustable stopper cables:

Weight: 5.5 kg Dimensions: 300 x 210 x 200 mm Volume: 0.01 m³

Uses of stopper cables:

These cables stop the rotation and/or translational motion of the high elasticity floors in GYMNOVA gymnastics sprung exercise floors (Ref: 6775 & 6775/DE - 6776 & 6776/DE - 6777 & 6777/DE - 6778 & 6778/DE).

I. Assembly of Anti-Rotation Kit: **1**

Locate the 2 holes on each corner panel - Left **(1)** and Right **(2)** (symmetrical floor): position of drilled holes for Anti-Rotation Kit attachments.

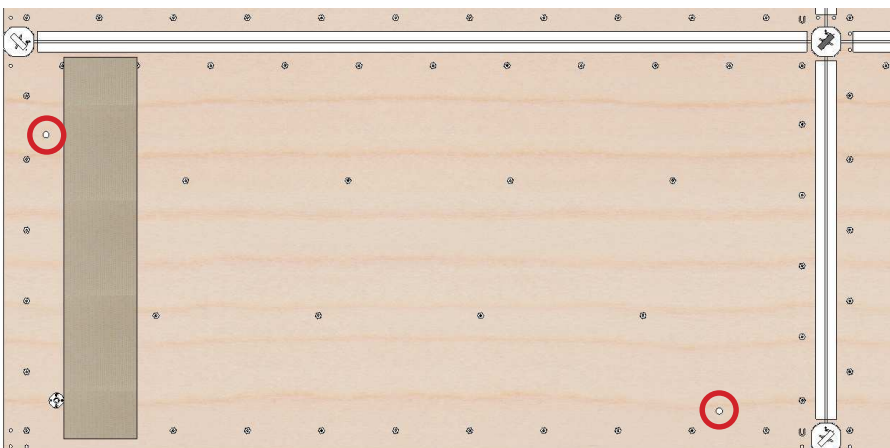
**2**

Pre-drill the flooring Ø12mm
through the holes of the panels
Drill bit, 200 mm usable length

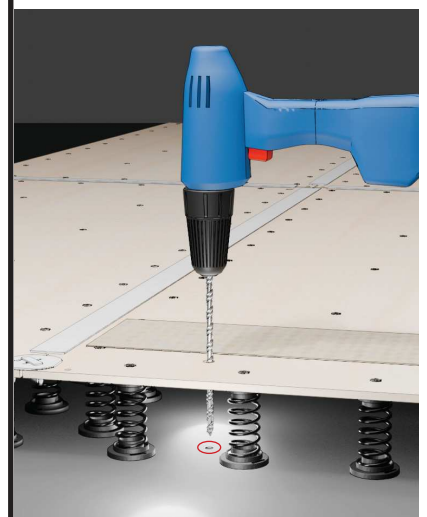

8

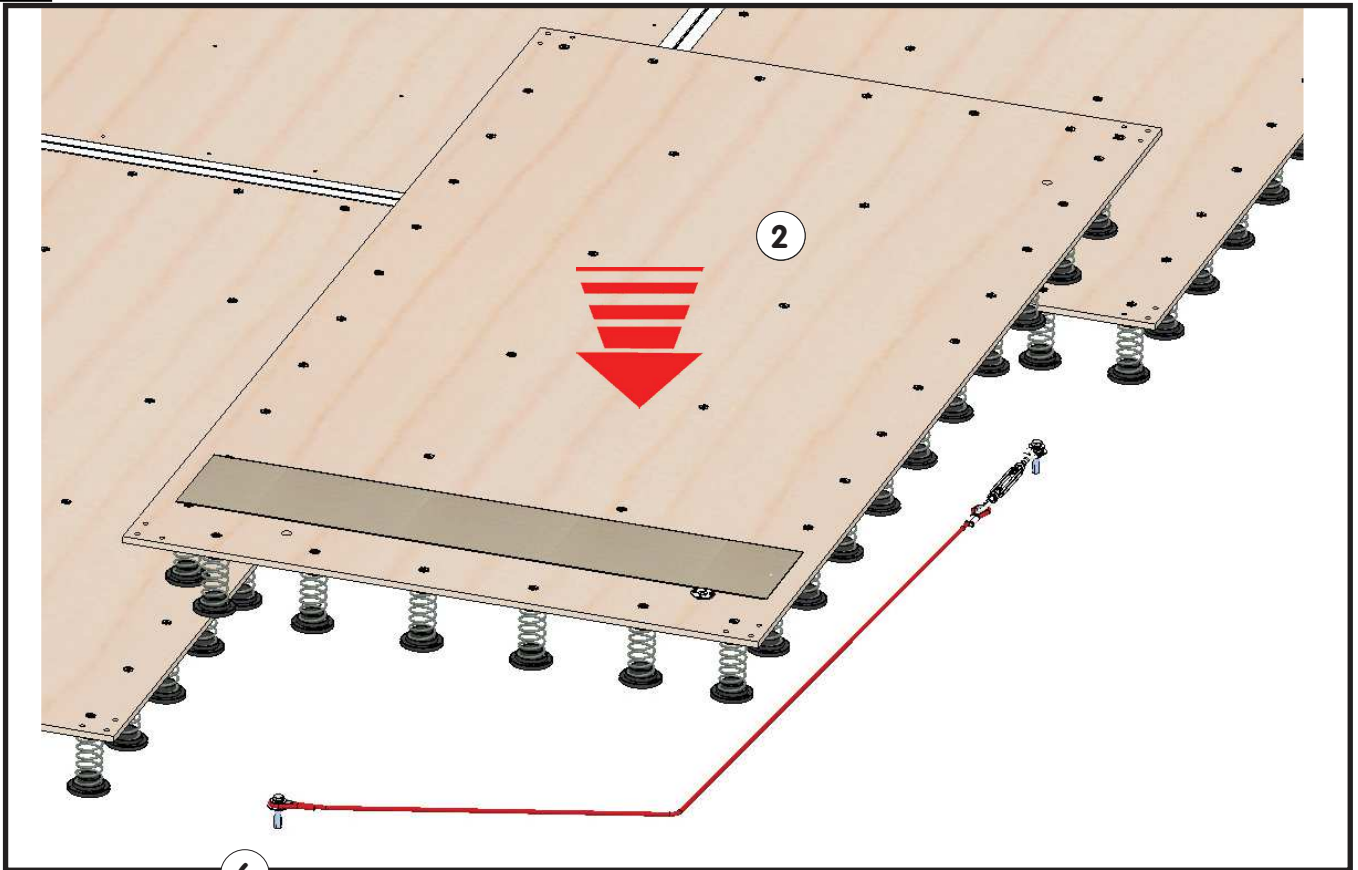

9

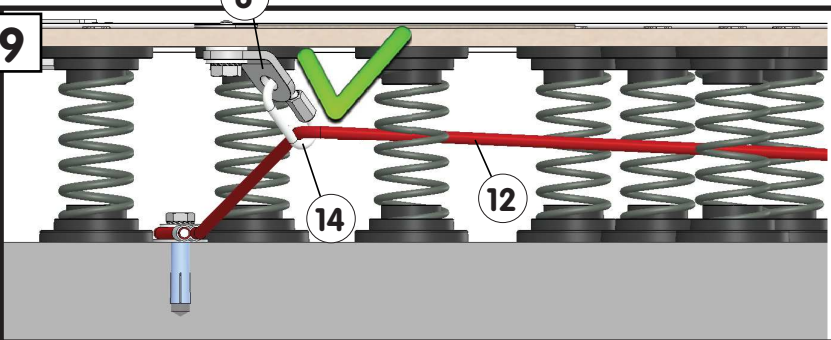

10

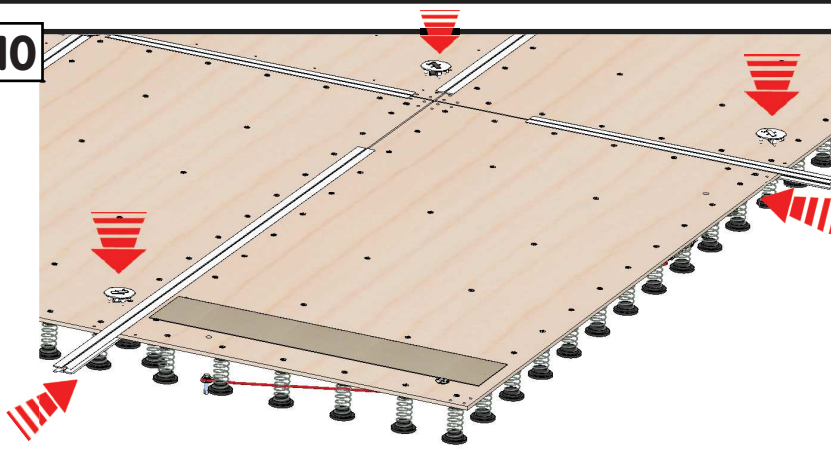

11

Screw in each tensioner (13) so that the cable (12) no longer rests on the floor. Firmly tighten the floor attachments (10, 9, 16 & 15). Hold the tensioner with a screwdriver and lock the locknuts with the spanner.

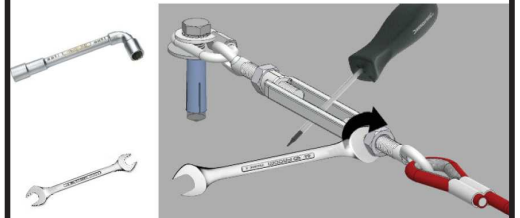

Tube spanner and open end spanner no. 16 or 17.

Maintenance:

- Regular cleaning of the floor will make it easier to spot any problems (distortion, breakage or corrosion).
- Before each use, make a thorough check on the condition of the components: wear of bracing flats (6), cables (12), quick links (14) and turnbuckles (13).
- Periodically check the tensioning of cables (11), locking of tensioners (13), and closure of quick links (14).
- Check that the attachments (15) are locked and that the bolts (17) are not coming away from the flooring.

Important :

- If a problem is found or suspected, do not use the equipment until it has been checked by a technician.
- Any damaged or distorted component should be replaced as quickly as possible.

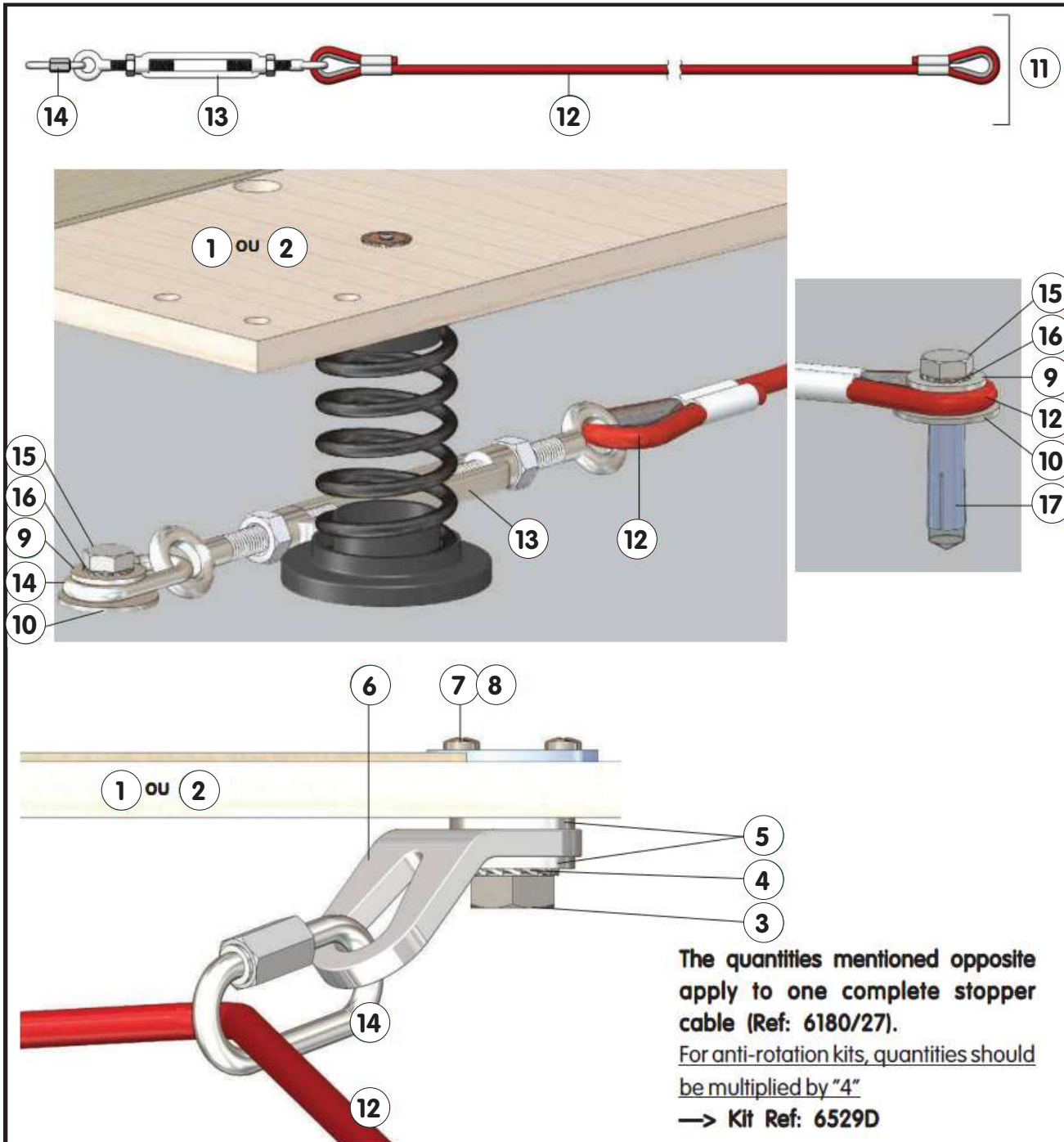

The quantities mentioned opposite apply to one complete stopper cable (Ref: 6180/27).
 For anti-rotation kits, quantities should be multiplied by "4"
 → Kit Ref: 6529D

To order spare parts, please provide the description, reference and delivery date of the entire

30	-	-	-	-
29	-	-	-	-
28	-	-	-	-
27	-	-	-	-
26	-	-	-	-
25	-	-	-	-
24	-	-	-	-
23	-	-	-	-
22	-	-	-	-
21				
20				
19				
18				
17	2	M10 hammer-type exp. bolt	QCEC100000	Floor attachments
16	2	External tooth lock washer dia. 10 x 18	VREE10180Z	Floor attachments
15	2	H M10 x 30 ZP screw	VH0010030Z	Floor attachments
14	2	Quick link No. 6	QMRA00006Z	included in 11
13	1	M10 O/O turnbuckle	QTELE1010G	included in 11
12	1	5.5 dia. cable - length: 2.26 m	-	included in 11
11	1	Adjustable stopper cable	-	each
10	2	LL 10 x 36 flat washer	VRP010360Z	Floor attachments
9	2	L 10 x 27 flat washer	VRP010270Z	Floor attachments
8	2	Pan-head chipboard screw, dia. 4 x 16	VVBZ40016Z	included in 1 and 2
7	1	M12 screw nut	VEAV12210Z	included in 1 and 2
6	1	Bracing flat	X3120/12	included in 1 and 2
5	2	LL 14 x 36 flat washer	VRP014360Z	included in 1 and 2
4	1	External tooth lock washer dia. 12 x 20	VREE12200Z	included in 1 and 2
3	1	H M12 x 25 ZP screw	VH0012025Z	included in 1 and 2
2	-	Right corner panel 2.33x1.16m	6792/13	-
1	-	Left corner panel 2.33x1.16m	6792/12	-
REP.	Qté	DÉSIGNATION	RÉFÉRENCE	OBSERVATIONS

**STOPPER CABLES AND ANTI-ROTATION
 KITS 14x14M & 12.85x12.85M
 FLOORS FOR «MONTREAL» SPRUNG EXERCISE FLOORS M'25**

Pour commander les pièces détachées, rappeler la désignation, la référence et la date de livraison de l'appareil complet.

Dans le souci d'une amélioration constante des produits, nous nous réservons le droit d'apporter des modifications techniques et dimensionnelles sans que cette notice nous soit opposable.

Ce document est la propriété de Gymnova, il est confidentiel et ne peut être reproduit sans accord.

FOAM UNDERLAY 14x14M «MONTRÉAL» COMPETITION & TRAINING SPRINGS EXERCISE FLOOR WITH ROLL-UP TRACKS M'25

6776/10
6776D - 6776D/DE
6778D - 6778D/DE



6776D & 6776D/DE

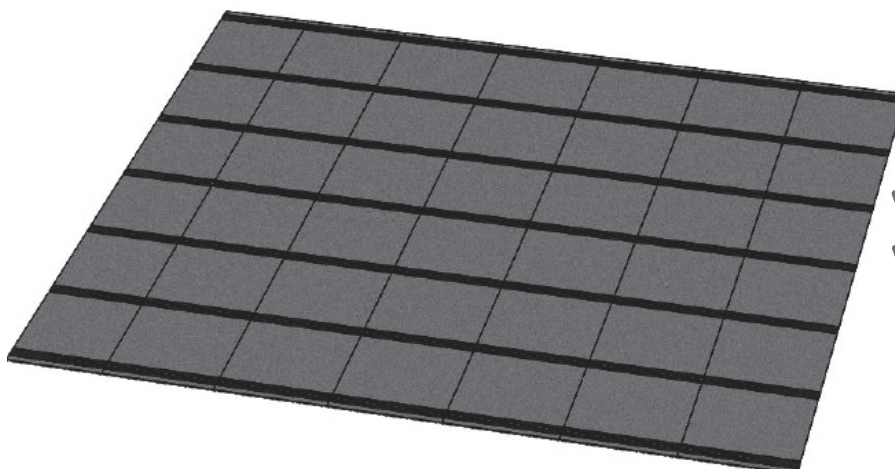

KEEP THIS DOCUMENT

Warning:

This equipment should be installed by a qualified individual. This equipment should only be used by one person at a time, under the supervision of a qualified individual.

Using this equipment for purposes other than those originally intended is prohibited.

Compliance:

14 x 14 m Exercise floors ref. 6776D and 6776D/DE are FIG approved.

Recommendations:

- keep these instructions for subsequent reference (inspection, maintenance, etc.).
- periodically carry out predictive maintenance.
- depending on how much it is used have the equipment serviced yearly or every few years.

Pack list:

PACK REF.	6542/00 7 joining strips for foam tracks	6586/10 Foam area ARK M13	6776/11 Foam roll 14 x 2.04m th. 24mm	6776/12 Set of 7 textile adhesive strips 14m	Number of packages
6776/10 Foam area 14x14m th: 24mm	1	1	7	1	10
VOLUME (M ³)	0.02	0.01	1.01	0.06	X
WEIGHT (KG)	2.1	1.1	21	8.5	
SIZE (MM)	360 x 260 x 180	310 x 210 x 190	2060 x 700 x 700	1000 x 300 x 200	

I. Maintenance :



IMPORTANT:

Leave the foam to rest for at least 48 h. The foam area overlaps the floor: cut off any necessary excess foam. Repeat the process if necessary (foam dimensions vary over time).

- Regular cleaning of the exercise floor makes it easier to spot any problems (distortion, breakage or moisture absorption).
- Check the condition of the foam rolls **(1)** and the anti-rotation kit **(2)**.
- Check the condition of the floor (wood panels, springs, plastic parts, sections and plates - **NM308** or **NM307**) of the gymnastics area with tracks **(NM286A)**.
- Any damaged or distorted component should be replaced as quickly as possible.

II. Disassembly and storage of the foam:

Carefully roll up the joining strips **(5)**, then fold the 7 foam tracks **(1)**. Store the stacked foam tracks flat in a clean, dry location. Do not store any heavy, protruding or other item on top. Avoid direct contact with the floor.

III. Assembling the underlay impact-absorbing foam area (6776/10) (👤👤 minimum).

Figures 1 - Installing the Anti-Rotation Kit of the foam area

Place each of the 4 strips of 150 x 25 cm black textile adhesive (2) on each self-gripping pad on the floor corners.

Important: wait the end of step II, to remove the protective film from the 4 strips (2)

14 x 14m Floor

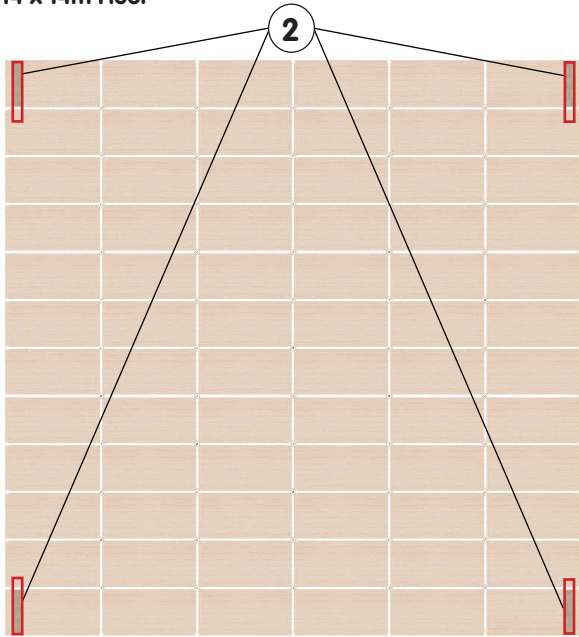

12.85 x 12.85m Floor

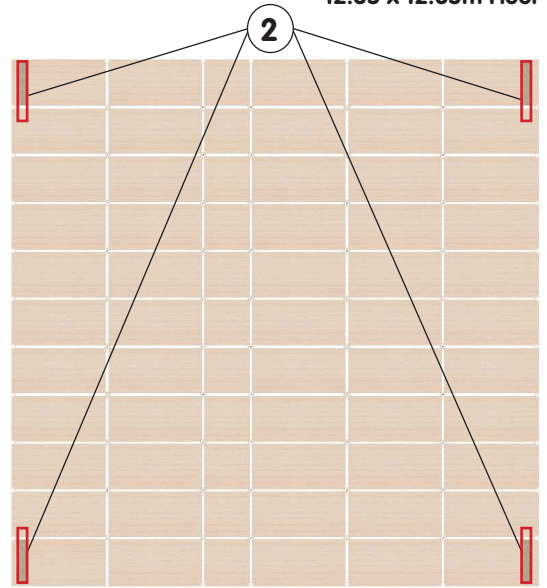

Figures 2 - Installing the foam area

Unroll foam rolls (1) from wooden floor plates layout

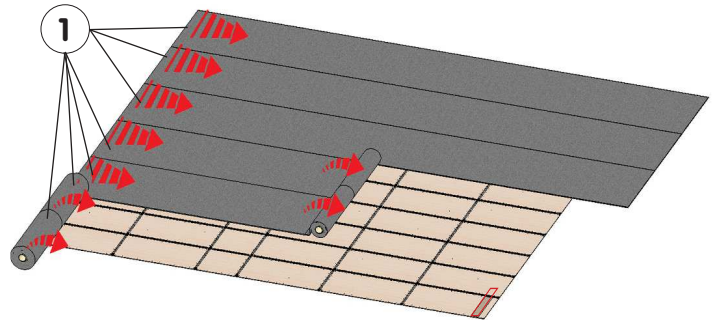
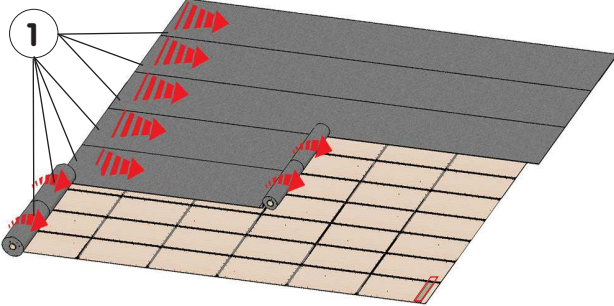

Figures 3 - Binding the foam area

Align these foam strips (1) with an **angle of the floor**. Bonding by 7 adhesive black textile strips (3) (length 14m - width 25cm)

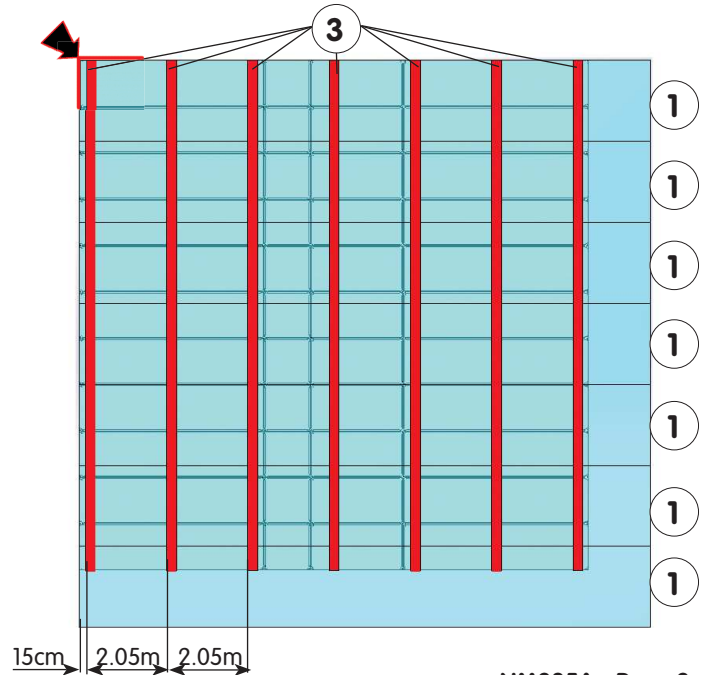
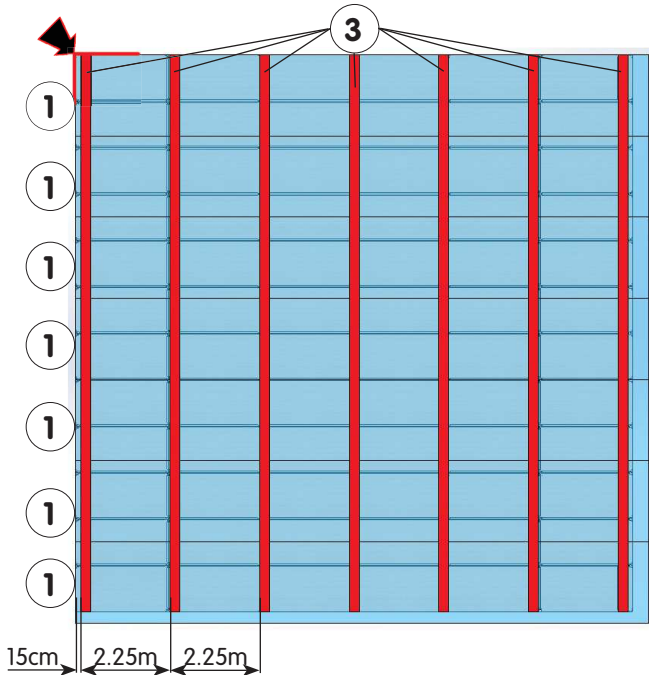

Figures 4 - Cutting the foam area

Cut the protruding part of the foam strips (1) from both sides of the floor edge.

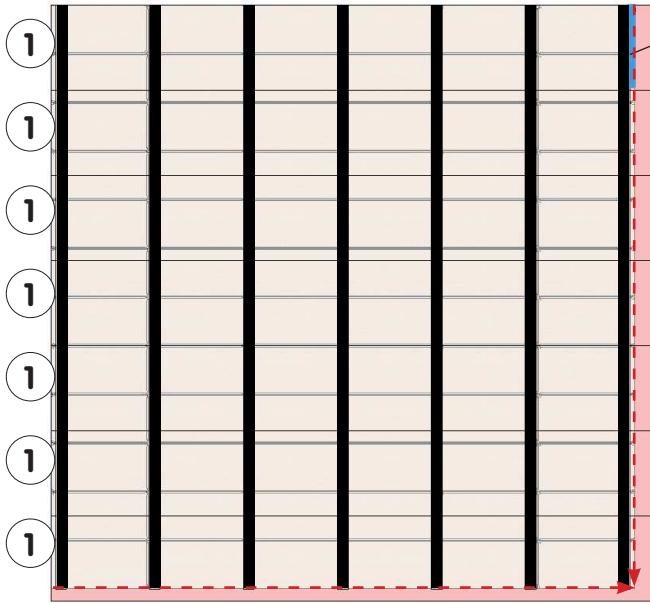

Figure 5 - Cutting the foam area detail

Cut the protruding part using the 2m (4) ruler (supplied with the roll-up tracks) and a cutter, along the wooden floor plates.

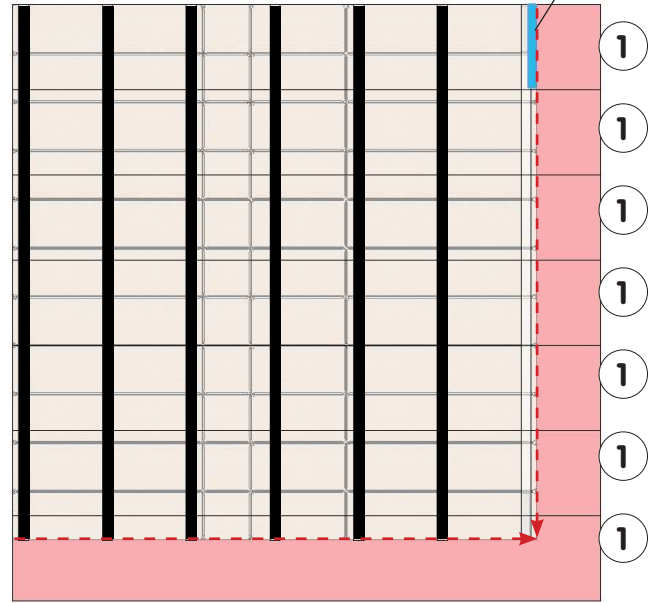
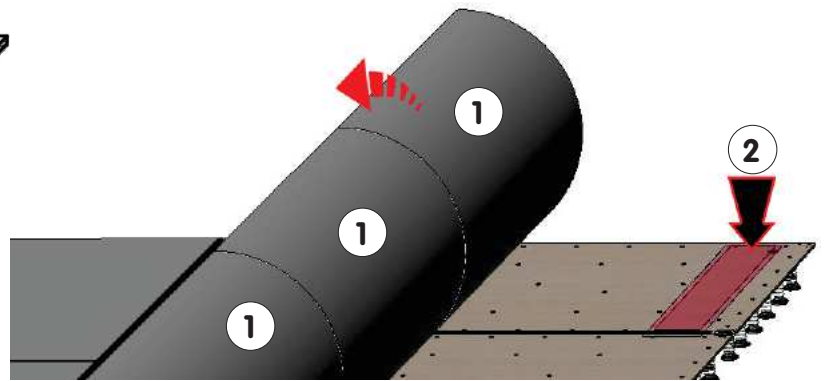
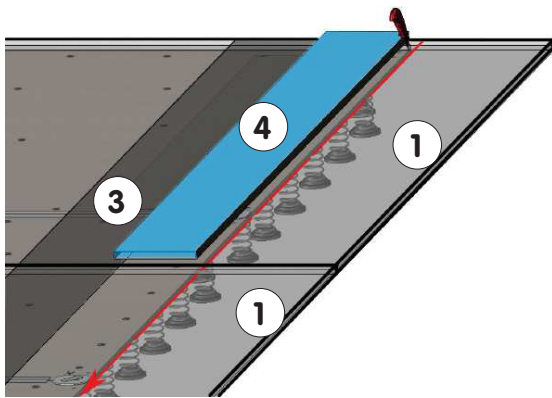

Figure 6 - Area foam ARK activation

Lift the foam strips (1) at the 4 corners of the floor, then remove the protective film from the 4 adhesive black textile strips (2).



Figures 7 - Foam area disassembly option

Cut the 7 black adhesive textile strips (3) between the foam strips (1) to separate them. Bind them thanks to 7 beige hook-and-loop strips (5) (5cm width - Length 12,50m)

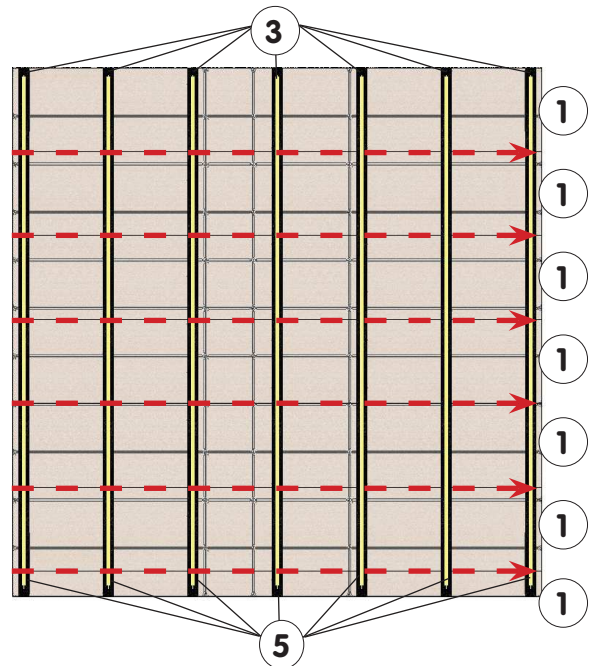
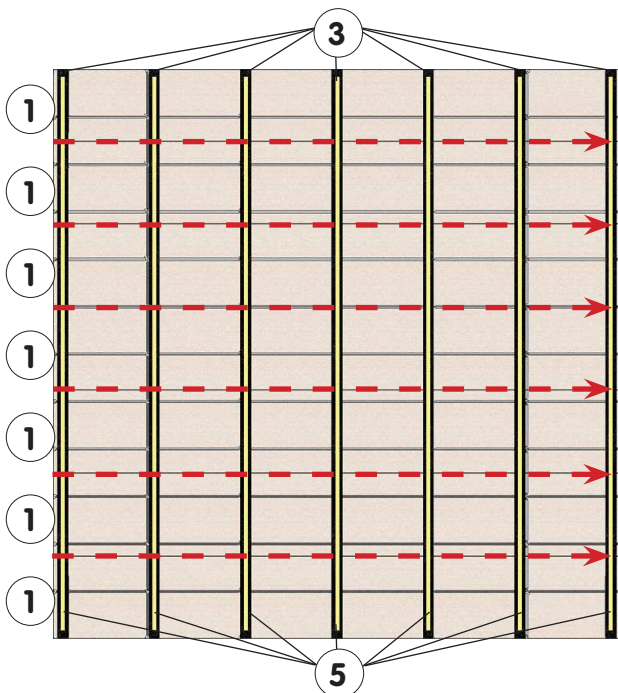

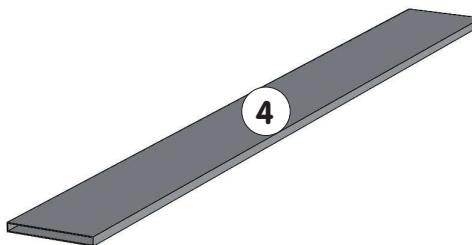
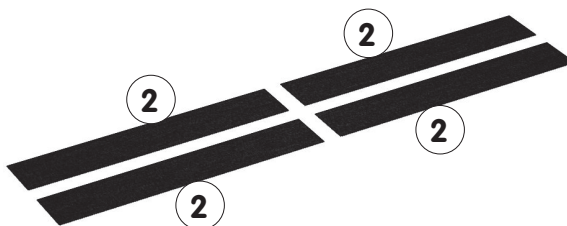
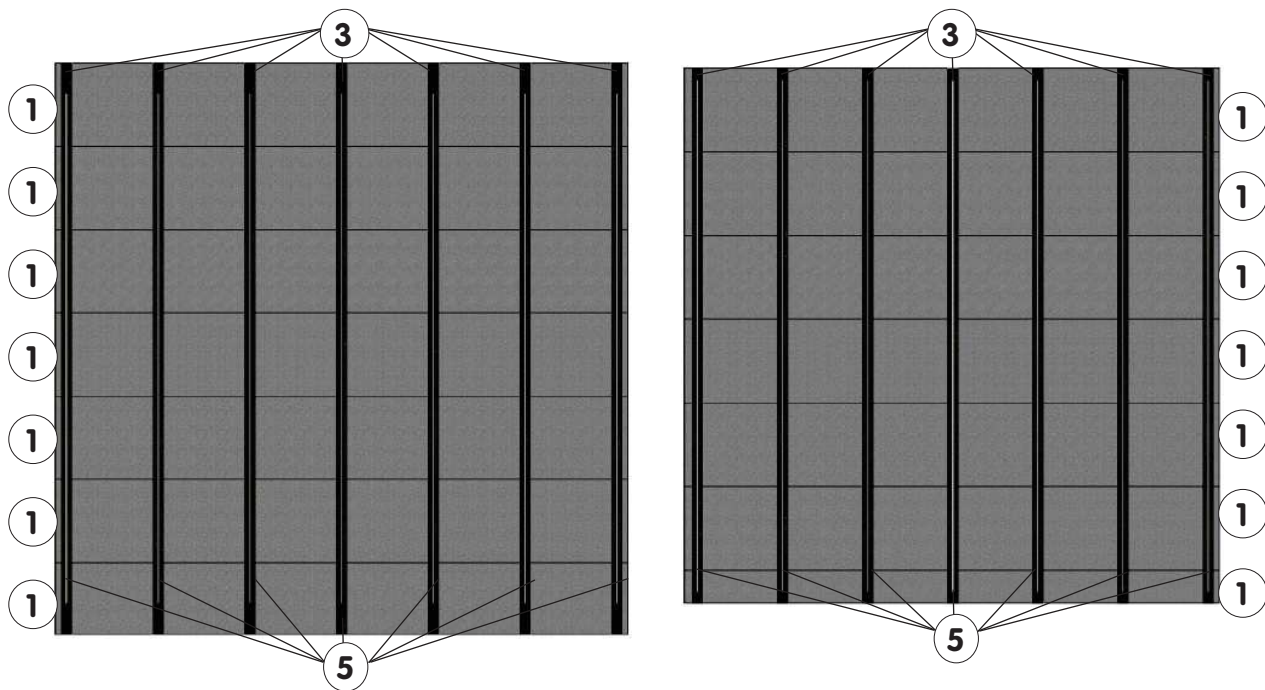

30	-	-	-	-
29	-	-	-	-
28	-	-	-	-
27	-	-	-	-
26	-	-	-	-
25	-	-	-	-
24	-	-	-	-
23	-	-	-	-
22	-	-	-	-
21	-	-	-	-
20	-	-	-	-
19	-	-	-	-
18	-	-	-	-
17	-	-	-	-
16	-	-	-	-
15	-	-	-	-
14	-	-	-	-
13	-	-	-	-
12	-	-	-	-
11	-	-	-	-
10	-	-	-	-
9	-	-	-	-
8	-	-	-	-
7	-	-	-	-
6	-	-	-	-
5	7	Beige hook-and-loop strip 5cmx12.5m	-	Inclu. in 6542/00
4	-	2m Ruler for cutting roll-up tracks.	6574/20	NM286A (6776/00)
3	7	Black adhesive textile strip 14mx25cm	-	Inclu. in 6776/12
2	4	Black adhesive textile pad 150x25cm	-	Inclu. in 6586/10
1	7	Roll-up foam 14x2m th.24mm	6776/11	6776D - 6778D
ITEM	QTY	DESCRIPTION	REFERENCE	REMARKS

FOAM UNDERLAY 14x14M
«MONTRÉAL» COMPETITION & TRAINING SPRINGS EXERCISE
FLOOR WITH ROLL-UP TRACKS M'25

To order spare parts, please provide the description, reference and delivery date of the entire apparatus.

Constantly aiming to improve our products, we reserve the right to make changes to the equipment and dimensions without further discussion.

This document is the property of Gymnova, it is confidential and shall not be reproduced.

GYMNASTICS AREA 14x14M & 12.85x12.85M «MONTRÉAL» COMPETITION & TRAINING SPRINGS EXERCISE FLOOR WITH ROLL-UP TRACKS M'25

6776/00 - 6778/30
6776D - 6776D/DE
6778D - 6778D/DE



6776D & 6776D/DE

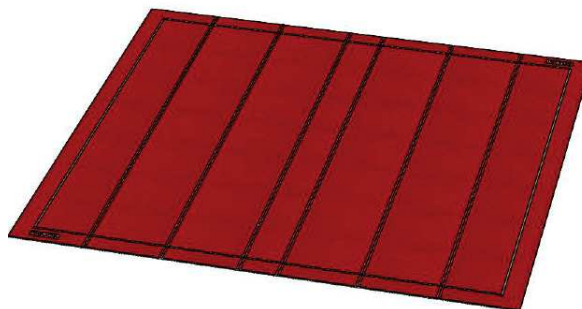
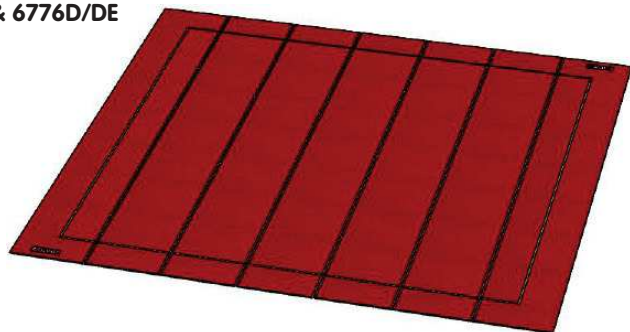

**KEEP THIS
DOCUMENT**

Warning:

This equipment should be installed by a qualified individual. This equipment should only be used by one person at a time, under the supervision of a qualified individual.

Using this equipment for purposes other than those originally intended is prohibited.

Compliance:

14 x 14 m Exercise floors ref. 6776D and 6776D/DE are FIG approved.

Recommendations:

- keep these instructions for subsequent reference (inspection, maintenance, etc.).
- periodically carry out predictive maintenance.
- depending on how much it is used have the equipment serviced yearly or every few years.

Pack list:

COLIS REF.	6776/01 14 x 2 m roll-up track, th. 38mm	6778/31 14 x 0.85 m roll-up track, th. 38mm	6574/20 Rule, length 2 m for cutting	6579/15 Spring exercise floors accessories	Number of packages
6776/00 14 x 14 m gymnastics area th: 38mm	7	-	1	1	9
6778/30 12.85 x 12.85 m gymnastics area th: 38mm	6	1	1	1	9
VOLUME (M³)	1.57	0.67	0.004	0.05	X
WEIGHT (KG)	61	27	2	6.3	
SIZE (MM)	2000 x Ø1000	850 x Ø1000	2000 x 100 x 20	500 x 350 x 300	

I. Maintenance:



IMPORTANT :

Leave the roll-up tracks to rest for at least 48 h. The gymnastics area overlaps the floor: cut off any necessary excess tracks Repeat the process if necessary (tracks dimensions vary over time).

- Regular cleaning of the exercise floor makes it easier to spot any problems (distortion, breakage or moisture absorption).
- Check the condition of the roll-up tracks **(1)** and **(2)**, and the anti-rotation kit **(3)+(4)**.
- Check the condition of the floor (wood panels, springs, plastic parts, sections and plates - **NM308** or **NM307**) and of the Foam underlay (**NM285AA**).
- Any damaged or distorted component should be replaced as quickly as possible.

II. Disassembly and storage of roll-up tracks:

Carefully roll up the joining strips **(5)**, then fold the 7 tracks **(1)**, or **(1)** and **(2)**. Store the tracks rolls flat in a clean, dry location. Do not store any heavy, protruding or other item on top. Avoid direct contact with the floor.

III. Assembling the gymnastics area: (👤👤 minimum).

- 14x14m th. : 3.8cm with roll-up tracks (Ref.: 6776/00). Set of 4 finishing bibs 14m (Ref.: 6575/10).
- 12.85x12.85m th. : 3.8cm with roll-up tracks (Ref.: 6778/30). Set of 4 finishing bibs 12.85m (Ref.: 6777/10).

Figures 1 - Installing the Anti-Rotation Kit of the gymnastics area

Glue the 8 two-by-two beige adhesive self-gripping strips of 200 x 5cm (3) on each side of the foam underlay. Cover them with the 4 strips of 150 x 25 cm black textile adhesive (4)

Important: wait the end of step III, to remove the protective film from the 4 strips (4)

14 x 14m underlay foam

12.85 x 12.85m underlay foam

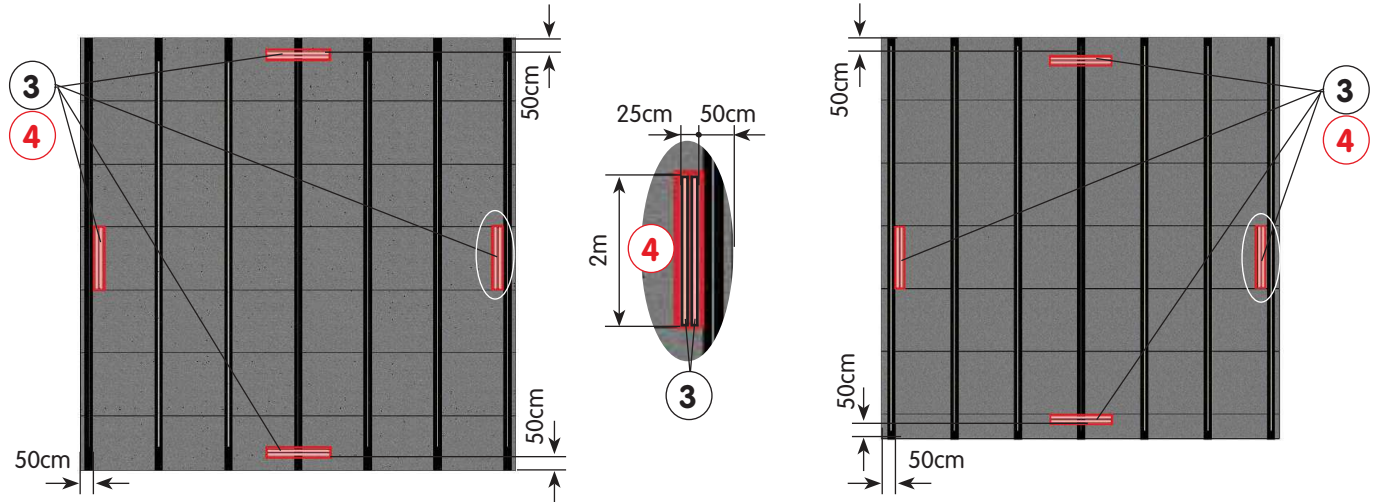

Figures 2 - Installing the gymnastics area

Unroll roll-up tracks (1), or (1) and (2) from area foam strips layout

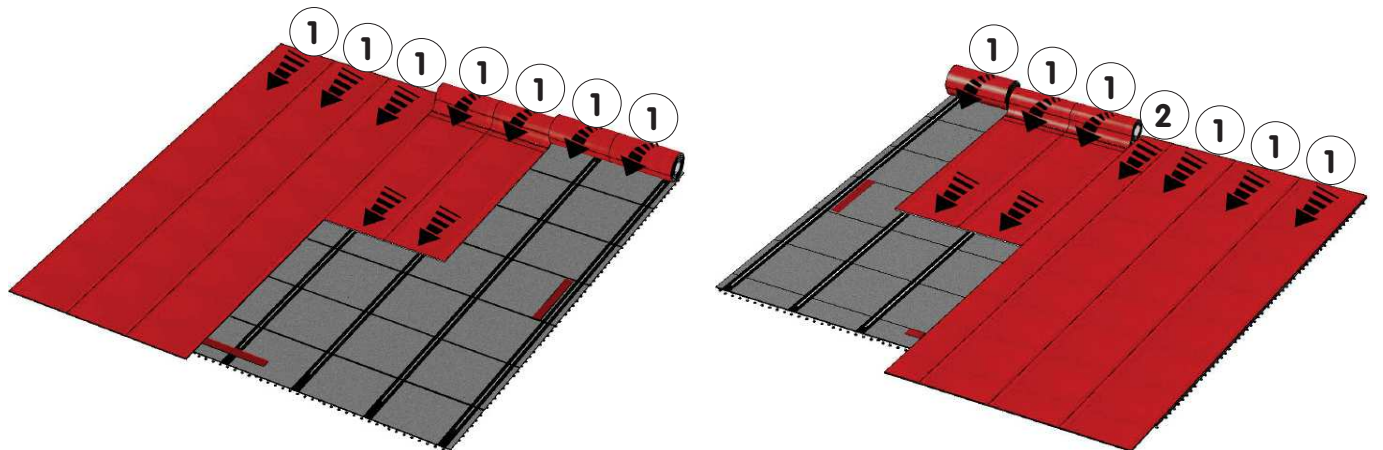

Figures 3 - Binding the gymnastics area

Align these roll-up tracks (1), or (1) and (2) with an **angle of the floor**. Bonding by 6 red self-gripping strips (5) (length 14m - width 10cm) straddling each track.

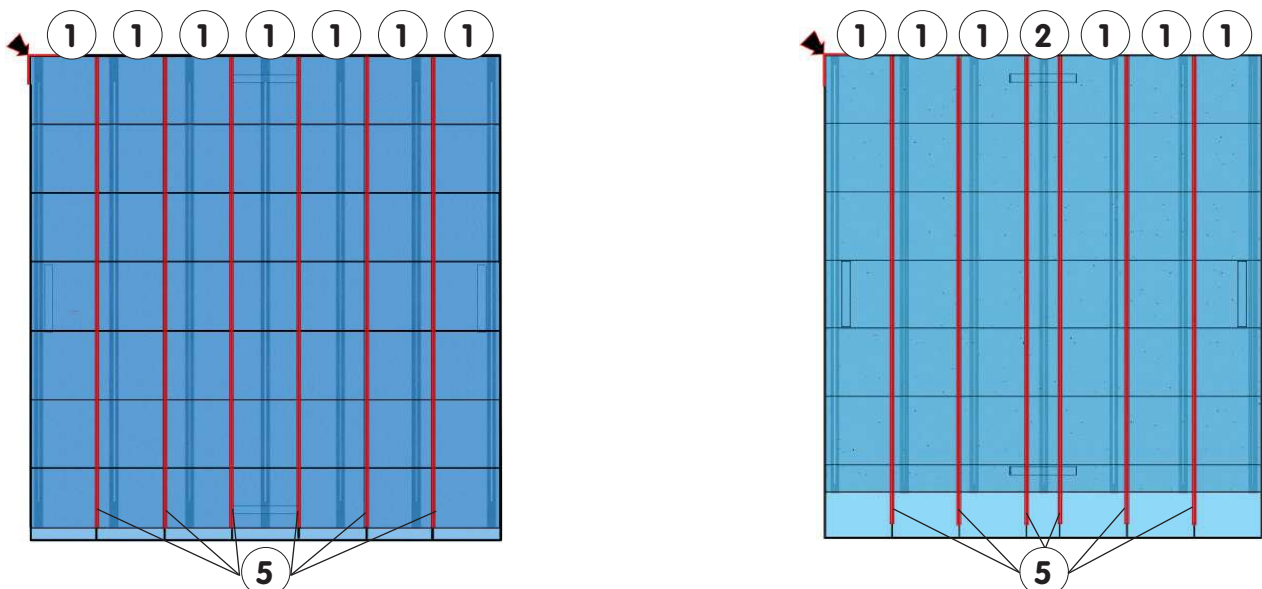

Figures 4 - Cutting the gymnastics area

Cut the protruding part of the extremity of the roll-up tracks (1), or (1) and (2) from the floor edge.

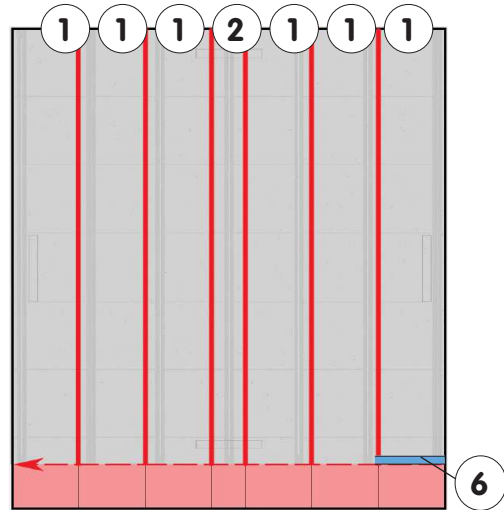
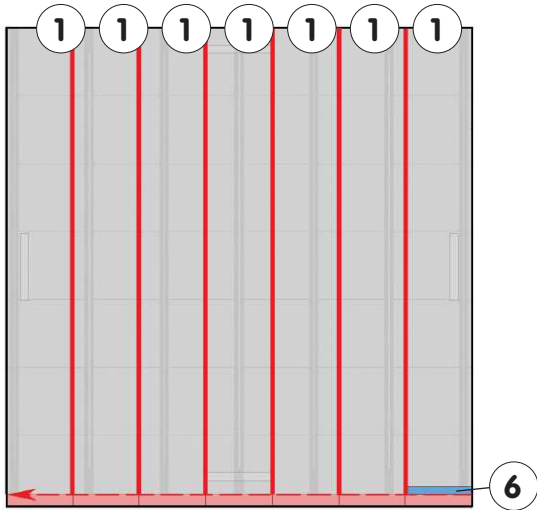
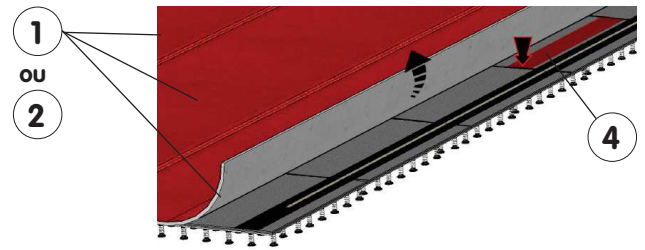
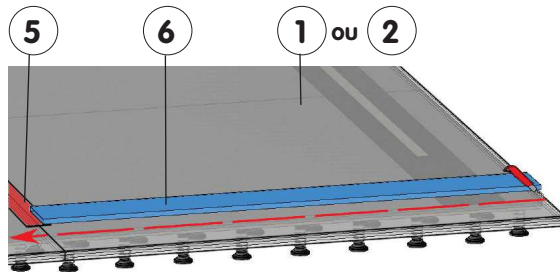

Figure 5 - Cutting the gymnastics area detail

Cut the protruding part using the 2m (6) ruler (supplied) and a cutter, along the wooden floor plates.

Figure 6 - Gymnastics area ARK activation

Lift the roll-up tracks (1), or (1) and (2) on the 4 sides of the floor, then remove the protective film from the 4 adhesive black textile strips (4).



Figures 7 - Gymnastics area markings

Place the 4 beige self-gripping strips (7) 5cm wide to define the 12 x 12m area of evolution.

Note: the strips are placed inside the zone. Position the 2 Gymnova markings (8) outside the zone of evolution.

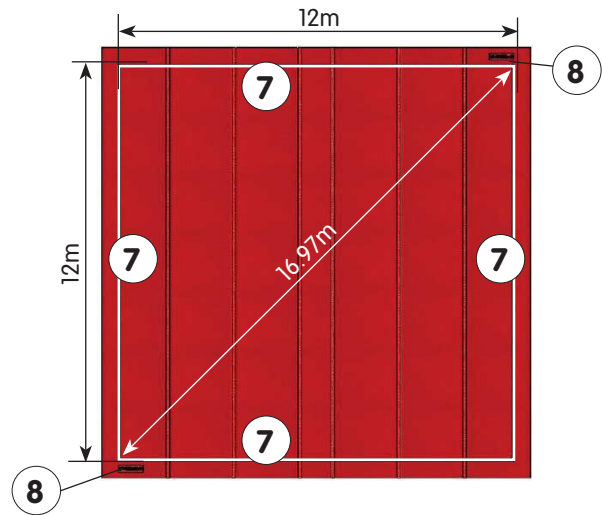
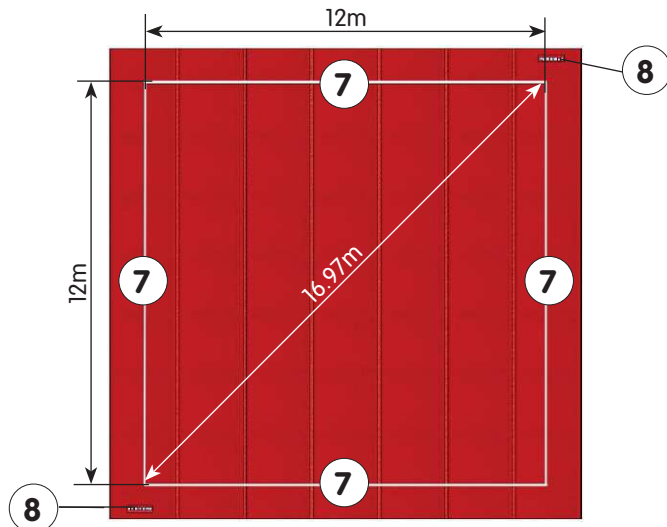

Figures 8 - Fitting of the exercise floor finishing bibs

Align the end (male self-gripping side) of one bib (9) or (9') on one corner of the exercise floor. Stretch and flatten on the first side of the exercise floor, plus angle feedback. Bind the second bib to the female hook-and-loop of the first and repeat the operation for the next 2.

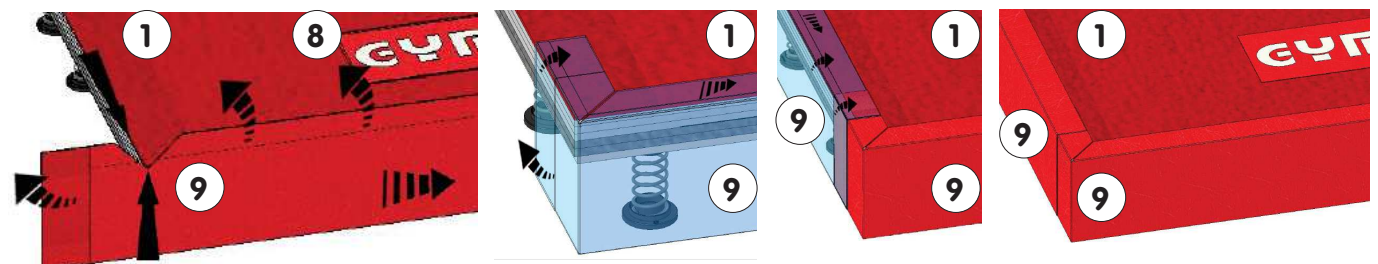

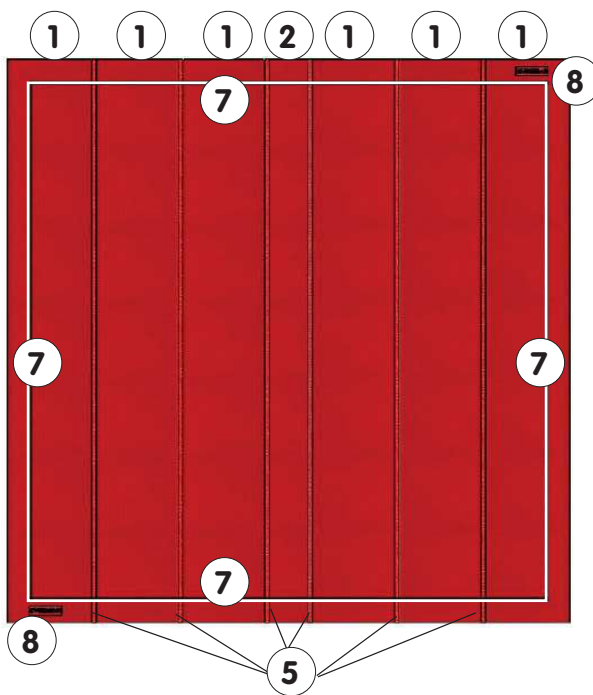
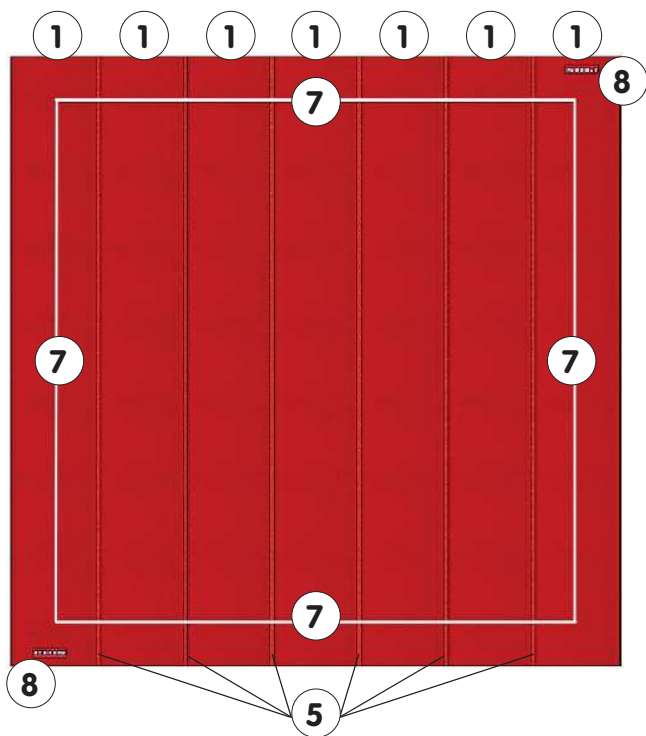

9

9'

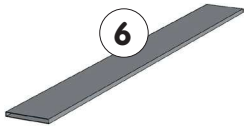
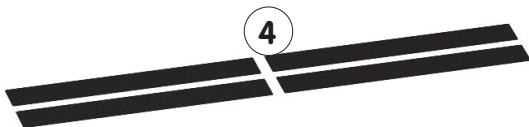
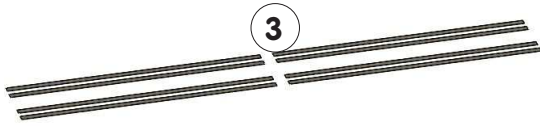
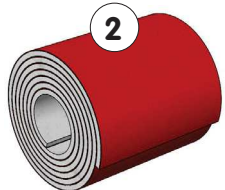
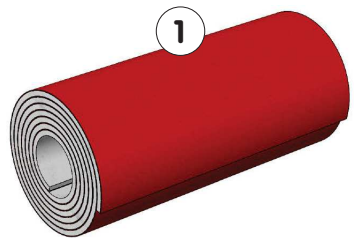

29	-	-	-	-
28	-	-	-	-
27	-	-	-	-
26	-	-	-	-
25	-	-	-	-
24	-	-	-	-
23	-	-	-	-
22	-	-	-	-
21	-	-	-	-
20	-	-	-	-
19	-	-	-	-
18	-	-	-	-
17	-	-	-	-
16	-	-	-	-
15	-	-	-	-
14	-	-	-	-
13	-	-	-	-
12	-	-	-	-
11	-	-	-	-
10	-	-	-	-
9'	4	Finishing bib of 12.85m	6777/11	6778D
9	4	Finishing bib of 14m	6575/11	6776D
8	2	Gymnova marking pad	6574/11	6776D - 6778D
7	4	Beige hook-and-loop strip 12mx5cm	-	6776D - 6778D
6	1	2m Ruler for cutting roll-up tracks.	6574/20	6776D - 6778D
5	6	Red male bonding strip 14.2mx10cm	6574/15	6776D - 6778D
4	4	Black adhesive textile pad 2mx25cm	-	6776D - 6778D
3	8	Beige hook-and-loop strip 2mx5cm	-	6776D - 6778D
2	1	Roll-up track 14x0.85m th.38mm	6778/31	6778D
1	7-6	Roll-up track 14x2m th.38mm	6776/01	6776D - 6778D
REP	NBR	DESIGNATION	REFERENCE	OBSERVATION

**GYMNASICS AREA 14x14M & 12.85x12.85M
«MONTRÉAL» COMPETITION & TRAINING SPRINGS EXERCISE
FLOOR WITH ROLL-UP TRACKS M'25**

To order spare parts, please provide the description, reference and delivery date of the entire apparatus.

Constantly aiming to improve our products, we reserve the right to make changes to the equipment and dimensions without further discussion.

This document is the property of Gymnova, it is confidential and shall not be reproduced.