

# PE HIGH BAR

Ref. : 690

## (UK) Assembly Instructions

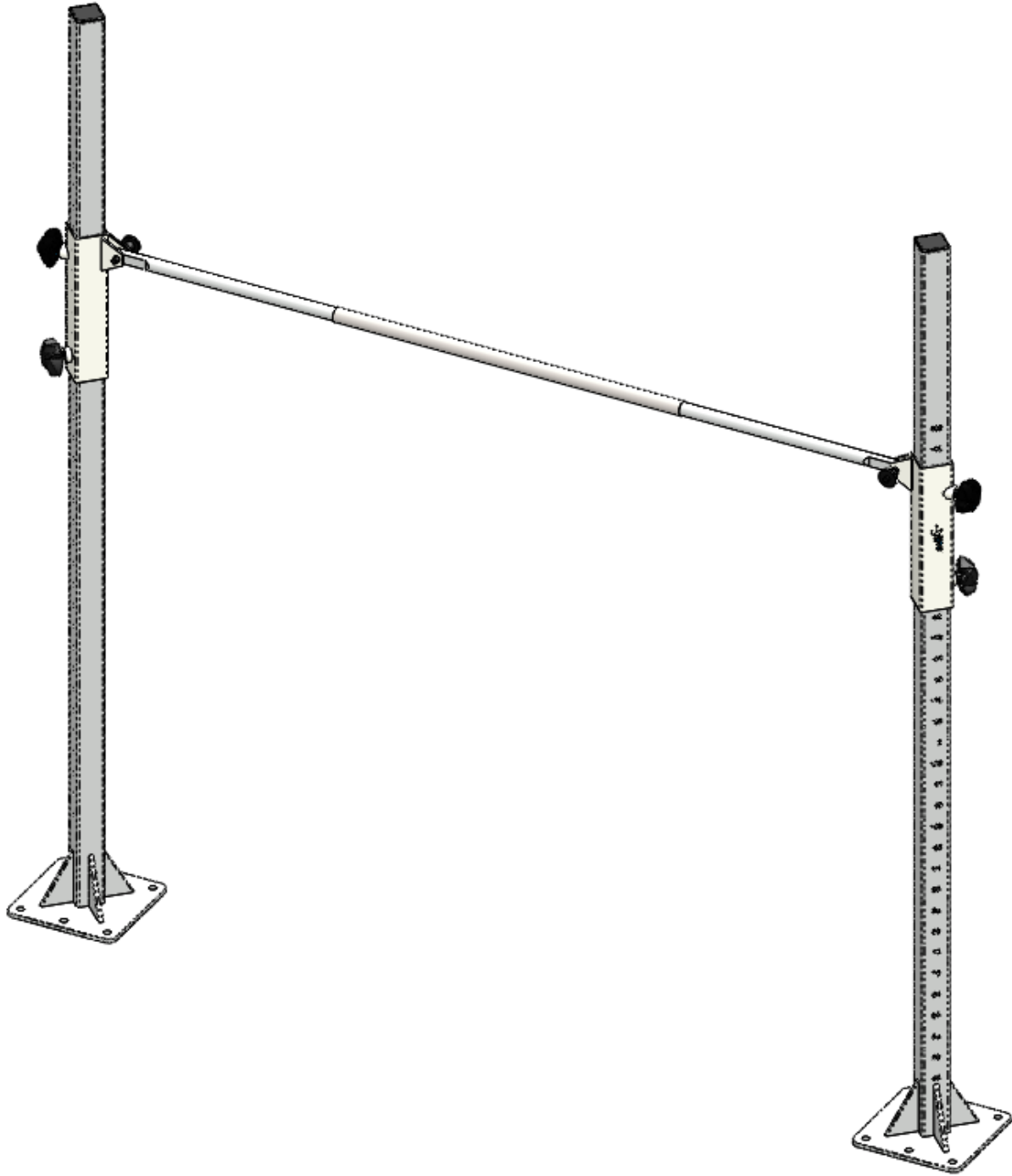

Thank you for buying this product O'jump. We advise you to read the assembly instructions carefully. The apparatus is presented in pre-assembled parts for a simplified assembly. We have designed this O'jump product to bring you complete satisfaction. If you need help, the O'jump team is at your disposal to accompany you.

 +33 (0)4 91 87 51 20  
 +33 (0)4 91 93 86 89  
 info@ojump.com

[www.ojump.com](http://www.ojump.com)

### Warning:



This equipment must only be used by one person at a time and under the supervision of a qualified individual, with appropriate landing mats.  
Using this equipment for purposes other than those originally intended is prohibited.

### Risk of injury from sudden fall of apparatus.

To avoid the apparatus tumble, the apparatus must fixed to the ground permanently.

The fixations are not included because their choice depending the ground material. Use the appropriate fixation according the support. To get advices or fixations sets contact the O'JUMP department.

### Recommendations:

- keep these instructions for subsequent reference (inspection, maintenance, etc.).
- periodically carry out predictive maintenance.
- depending on how much it is used, have the equipment serviced yearly or every few years.

### Footprint and weight:

- Apparatus 280x25cm (Lxl) poids 47Kg



Tools needed to assemble the apparatus.



Hardware listing (pre-assembled)

X2



Indexing pin

X2



Tightening knob

X2



indexing knob



## List of parts (pre-assembled)

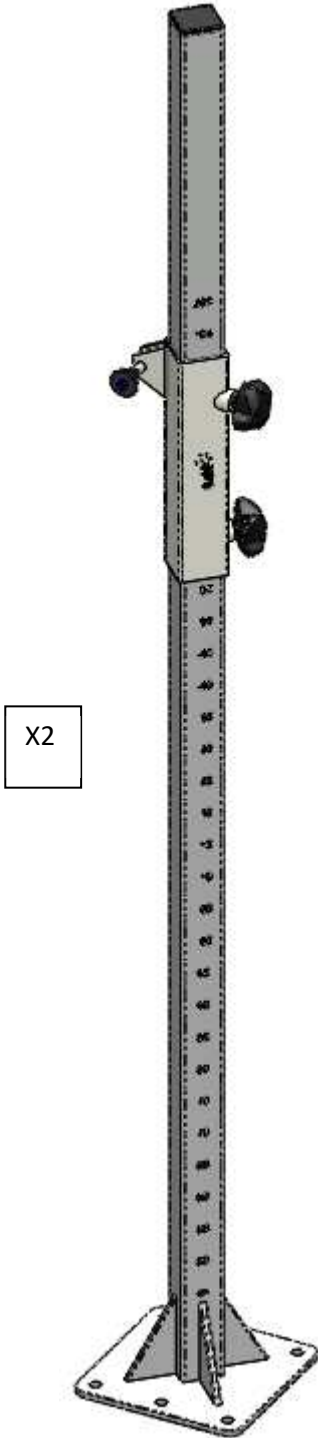

High bar uprights (2 packages)

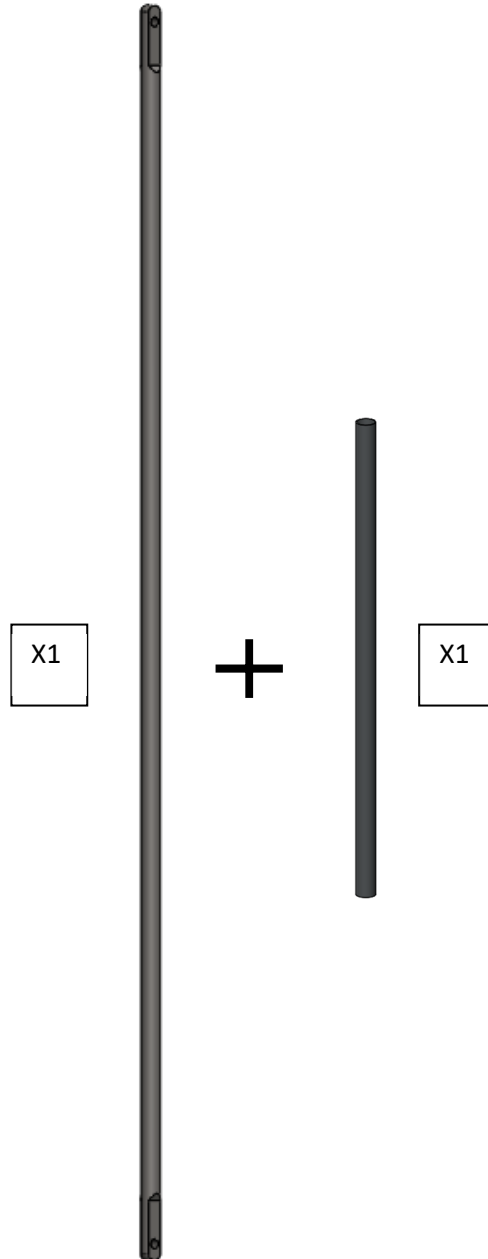

Steel hand-rail + Steel tube (1 package)

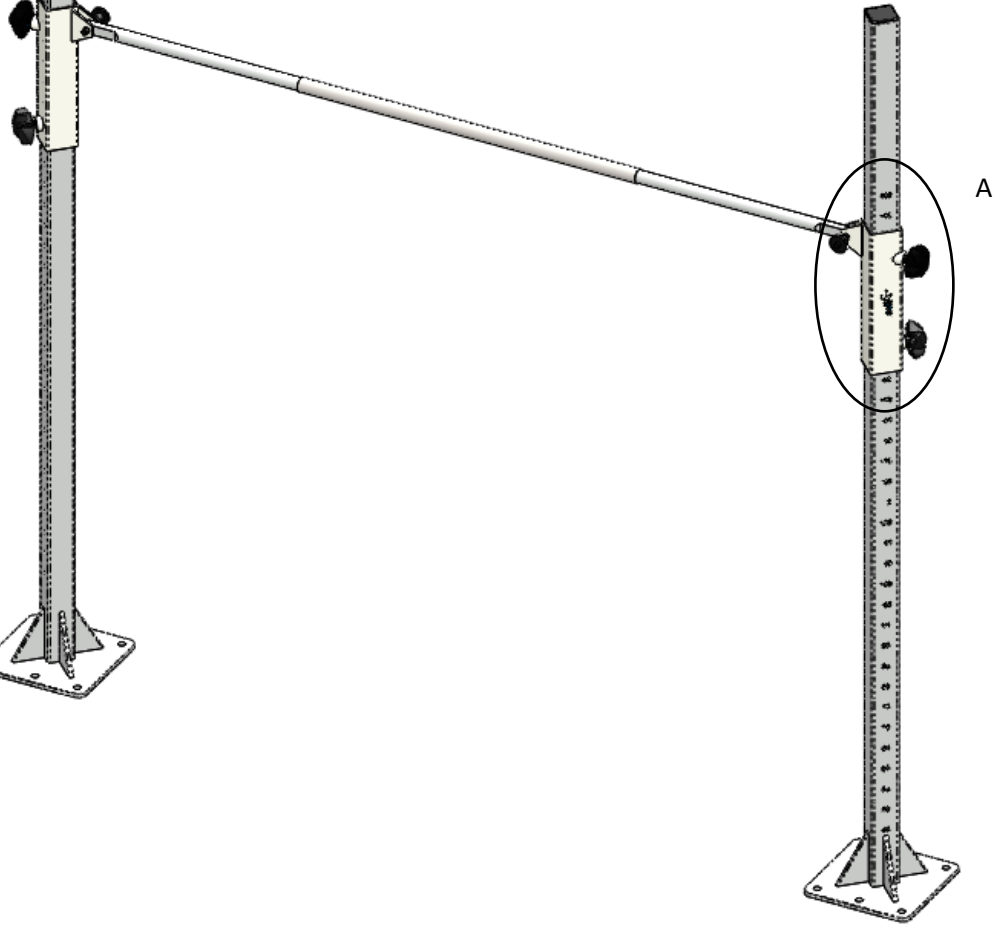
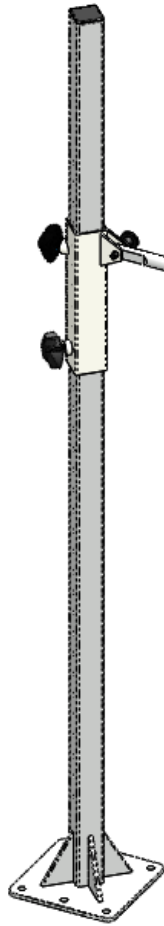

To insert the indexing pin, press the blue button to release the ball.

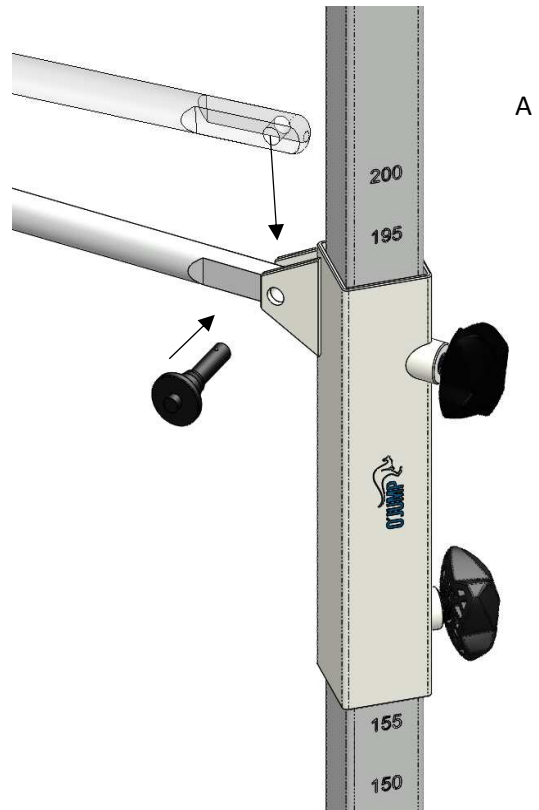
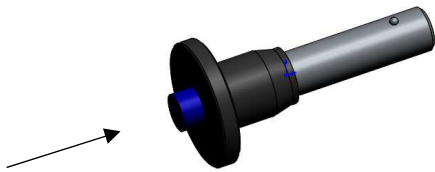

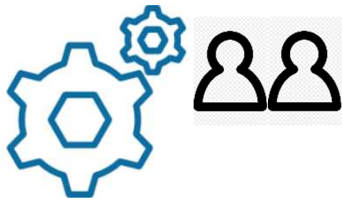

## Height adjustment

Unscrew the tightening and indexing knobs. Pull the indexing knob to release the slide.

Slide it down or up. Release the indexing knob in front of the desired position. Lock the two knobs by tightening.

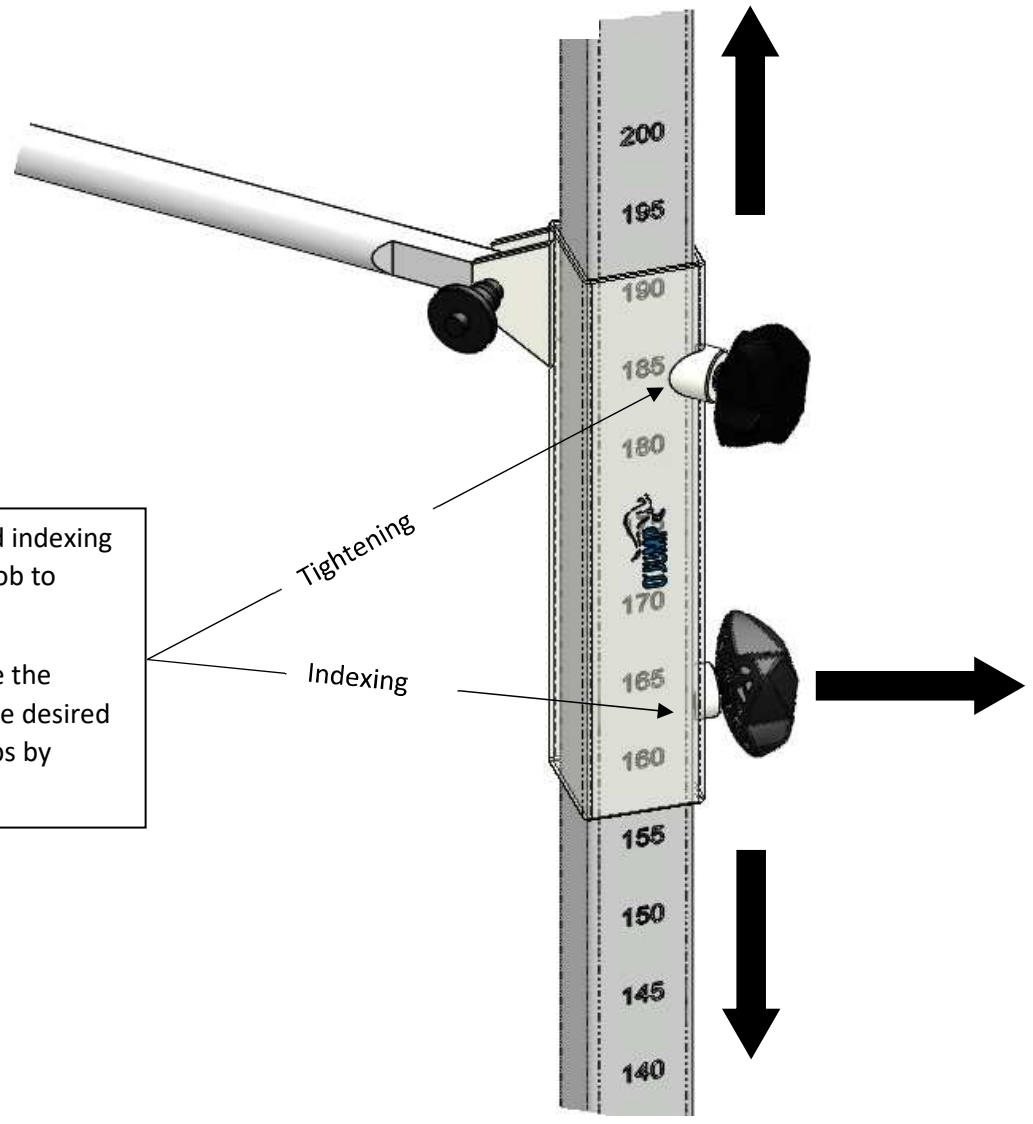

### Warning:

Safety is always the main consideration when setting up an apparatus.

- It is important to always have a good understanding of the task.
- Use common sense.
- . Always hold the slide with one hand when unscrewing the knobs
- . Risk of injury from sudden fall of the slide

## Fixing the high bar to the ground

Material required :



A bubble level



A drill



anchors adapted to  
your support



Screws adapted to  
your support

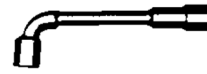

Wrench adapted to  
your type of screws



Pencil



Check with the O'JUMP service specifying the nature of your support. The type of anchors and screws depending on whether your floor is concrete, wooden floor, flexible ground...

1. Put the hand-rail in the low position and adjust the verticality of the uprights with the bubble level. Check the correct alignment of the uprights.

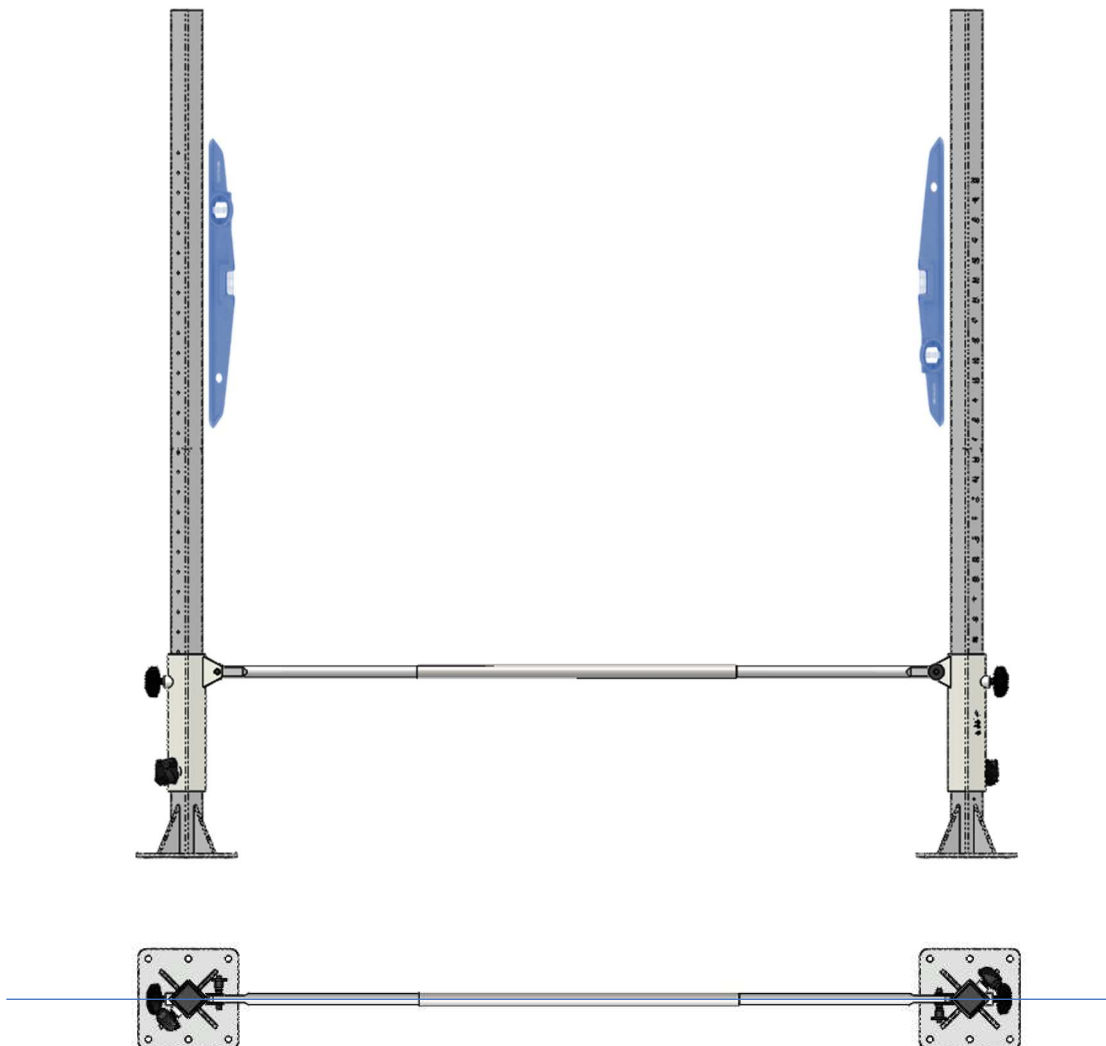

2. With a pencil, trace the location of the 4 holes for each plate.  
**(Do not use the middle holes)**

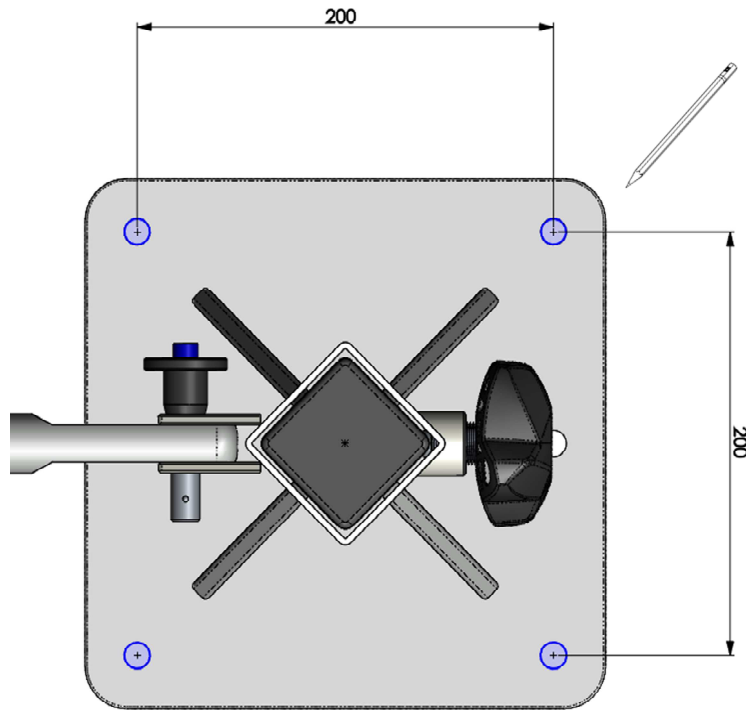

3. Drill all the holes using a drill bit appropriate for your floor. Place the fixations in the holes. They should not be higher than the ground.

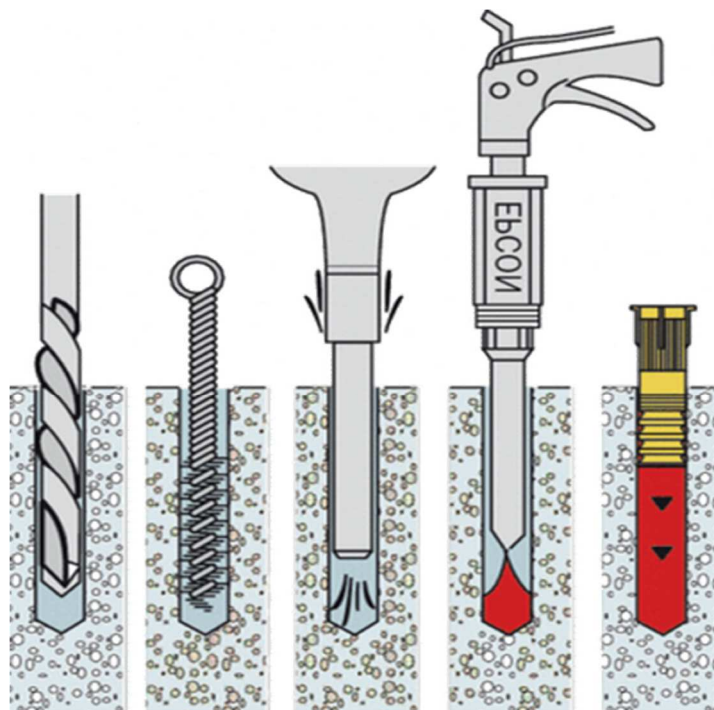

- Put in place the uprights in front of the 4 holes, then fix the uprights with appropriate screws.

